



Service Manual

S-6300

3 HP Automatic Euro 2" dia. Post Mount
Doctor's System with Flex Arm

S-6300/S-6307

Installation

1. Install the chair adapter as per instructions provided with the chair adapter.
2. Place the shipping carton in the desired location. Remove the unit with arm system and unit from the shipping carton.
3. Insert the unit post into the chair adapter hub. Level, then tighten the set screws to secure the post in place.
4. Place the adapter in the unit post and insert the umbilical into the unit post, pulling it out through the bottom. Slide the arm knuckle into the adapter.



WARNING

The arm system is spring loaded. Before removing the safety tie strap, firmly grasp the flex arm and hold down.

5. Cut the safety tie strap and carefully release the arm system.
6. Rotate the flex arm 180° in a counter-clockwise direction so that the umbilical tubings do not become crimped or twisted.
7. Remove the rigid arm end cap and tighten the cap screw to set the stop limits for the flex arm. Replace the end cap.

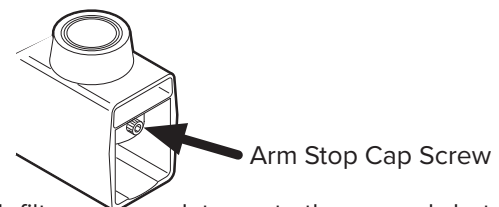

8. Install master valve assemblies, with filter and regulator, onto the manual shut-off valves. (Pressures are preset at the factory: 80 lbs. air, 40 lbs. water).
9. Feed the supply tubings from the umbilical through the 3/4" hole in the utility center housing. Screw in the spiral tubing to act as a strain relief.
10. Connect the supply tubings as shown in the Utility Center Template & Guide.

Final Adjustments

- Check air pressure, adjust to 80 psi if necessary.
- Check water pressure, adjust to 40 psi if necessary.
- Test handpieces for proper function.
- Test syringe for proper pressure and function.
- Adjust flex arm tension, if necessary.

S-6300/S-6307

Operation

1. Turn on the master switch located on the left side of the control head.
2. The handpiece is automatically activated when the wand is pulled forward.
3. Depress the foot control to activate each handpiece. Pressure is shown on the gauge for the handpiece being used.
4. Individual handpiece pressure adjustments are located on the autoblock inside the control head. To adjust the pressure to each handpiece:
 - a. Turn adjustment screw *clockwise* to decrease the handpiece pressure.
 - b. Turn adjustment screw *counter-clockwise* to increase the handpiece pressure.



CAUTION

When adjusting the handpiece pressure, do not over-tighten the screws. Damage may result.

5. Activate the water spray to the handpiece by flipping the toggle for the water located on the right side of the control head.
6. Water coolant flow adjustments are located underneath the control head.
7. Arm brake switch is located on the right side of the control head. The brake is on when the toggle is positioned towards the rear (right position). Pull the lever forward (left position) to release the arm brake, adjust arm to desired location and move lever to the rear (right position) to reapply the brake.

Handpiece Purge

The purge switch, located on the left side of the control head, flushes fresh water through the water coolant system. Guidelines from the Center for Disease Control (CDC) recommends that each handpiece be flushed (purged) 20 to 30 seconds between patients and several minutes at the beginning of each day. Handpieces must be removed from the holder to activate the purge system.

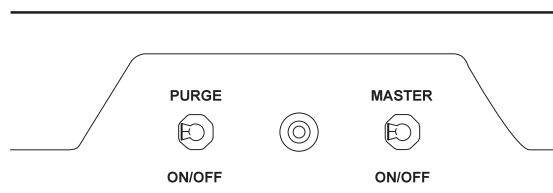

Control Panel–Left Side

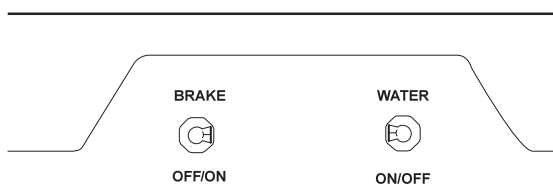

Control Panel–Right Side

Troubleshooting

Symptom Handpiece lacks power.

- Possible Causes
- A. Improper supply pressure from compressor (80 psi).
 - B. Check handpiece pressure adjustment on unit.
 - C. Air filter may be plugged.
 - D. Pinched supply tubing.
 - E. Defective handpiece gasket at connection with tubing.
 - F. Defective handpiece.

Symptom Water coolant does not shut off when foot control is released.

- Possible Causes
- A. Adjust air pressure to 80 psi—water pressure to 40 psi.
 - B. Foot control is not exhausting.
 - C. Defective water relay valve.

Symptom More than one handpiece is operating.

- Possible Causes
- A. Handpiece is not all the way in the holder.
 - B. Improper adjustment on pilot valve in the handpiece holder.
 - C. Defective shuttle valve to gauge.

Symptom Insufficient water coolant.

- Possible Causes
- A. Adjust coolant flow valve.
 - B. Water filter may be plugged.
 - C. Handpiece may be plugged.
 - D. Pinched supply tubing.
 - E. Improper adjustment of water relay valve.

Symptom Water coolant is running from handpiece while in the holder.

- Possible Causes
- A. Water pressure too high.
 - B. Air pressure too low.
 - C. Handpiece holder out of adjustment.

Symptom Water coolant is running continuously.

- Possible Causes
- A. Purge switch is on (on applicable systems).
 - B. Water pressure too high.
 - C. Handpiece holder out of adjustment.
 - D. Defective water relay valve.

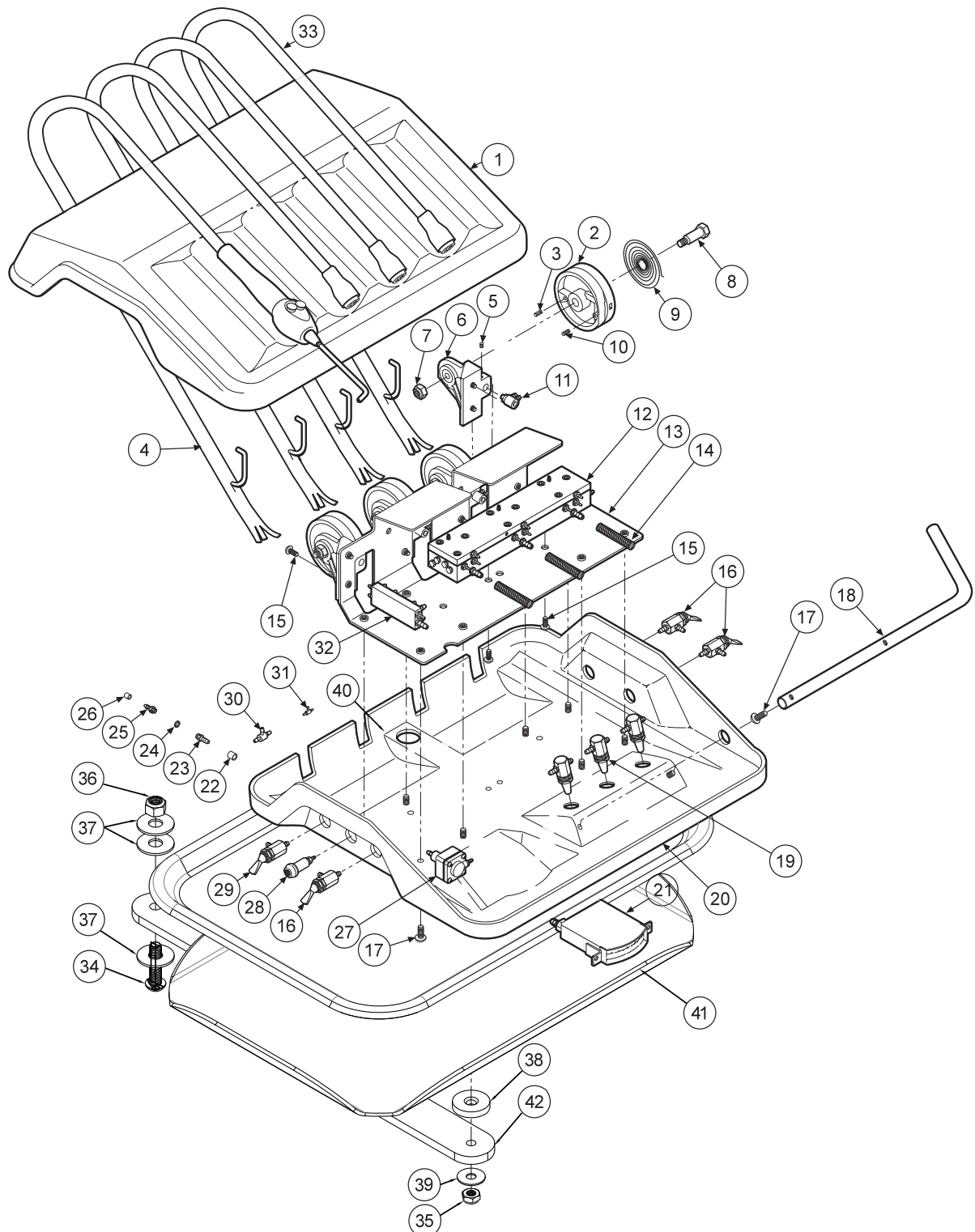

ITEM	PART DESCRIPTION	PART NUMBER	QTY	ITEM	PART DESCRIPTION	PART NUMBER	QTY	ITEM	PART DESCRIPTION	PART NUMBER	QTY
1	Cover.....	107-092	1	15	Screw, 6-32 x 3/8".....	001-041	10	29	Momentary Valve	120-005	1
2	Euro Cam	116-001	4	16	3-way Toggle Valve	120-000	3	30	Shuttle Valve.....	014-012	1
3	Pin, 1/8" x 1/2".....	009-029	4	17	Screw, 10-32 x 3/8".....	001-070	4	31	Plastic Tee, 1/16".....	022-033	2
4	Euro Wand Assembly	116-008	1	18	Holder Bar	107-093	1	32	Handpiece Manifold.....	023-001	1
5	Set Screw, 4-40 x 3/16".....	005-001	4	19	Needle Flow Valve	121-000	4	33	Euro Wand Assembly	116-009	4
6	Euro Cam Bracket	116-002	4	20	Base	107-091	1	34	Screw, 5/16-18 x 1-1/4".....	001-184	1
7	Nylon Locknut, 10-32	002-027	4	21	Gauge	026-003	1	35	Nut 1/4-20.....	002-023	1
8	Euro Pivot Shaft.....	116-005	4	22	Ferrule, 1/4".....	117-008	5	36	Lock Nut, 5/16-18.....	002-033	1
9	Euro Cam Spring.....	008-033	4	23	Barb, 10-32 x 1/8".....	022-010	4	37	3/8 Nylon Washer	003-010	3
10	Set Screw, 6-32 x 3/8".....	005-012	4	24	Plastic Washer, 1/4".....	003-001	14	38	Tray Mount Spacer Washer.....	003-022	1

**AUTOMATIC HANDPIECE CONTROL
S-6300/S-6307(28" POST MOUNT)**

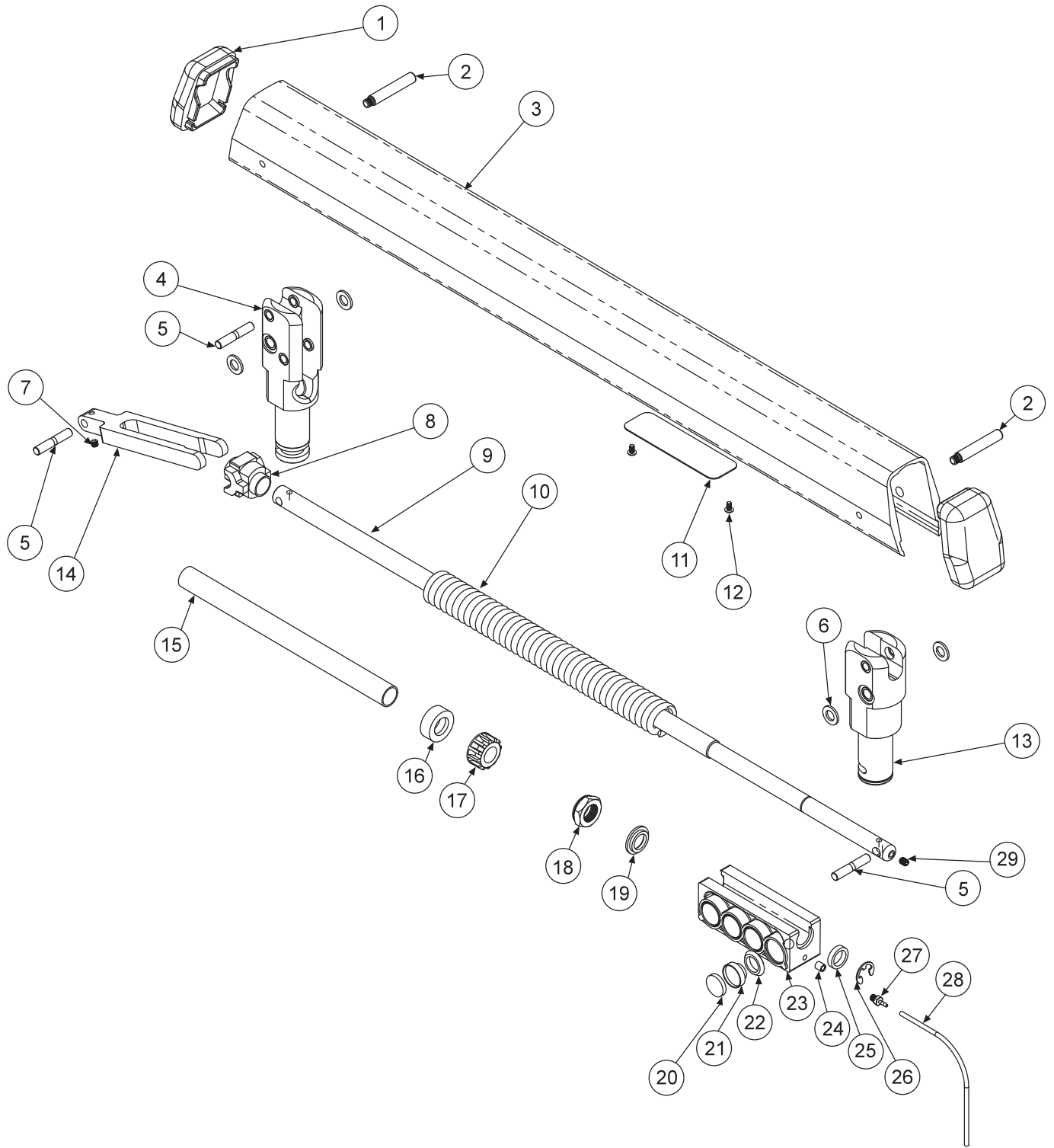

ITEM	PART DESCRIPTION	PART NUMBER	QTY	ITEM	PART DESCRIPTION	PART NUMBER	QTY	ITEM	PART DESCRIPTION	PART NUMBER	QTY
1	End Cap.....	106-319	2	11	Plug Adjustment.....	106-329	1	21	Piston, Brake.....	106-317	8
2	Pin, Arm Housing.....	009-030	2	12	Screw, 6-32 x 1/4".....	001-133	2	22	U-Cup.....	017-204	8
3	Arm Housing.....	106-314	1	13	Head Knuckle.....	106-337	1	23	Brake Housing.....	106-316	1
4	Arm Knuckle.....	106-322	1	14	Arm Fork Link.....	106-318	1	24	Ferrule, Delrin, 1/8".....	117-007	1
5	Pin Rod.....	009-031	3	15	Sleeve.....	106-321	1	25	Brake Collar, Threaded.....	106-324	1
6	Plastic Washer.....	003-040	4	16	Seat, Flex Arm Spring.....	106-320	1	26	Ring, Truarc, 5133-43.....	006-004	1
7	Set Screw, 10-32 x 3/16".....	005-037	1	17	Adjustment Nut.....	106-325	1	27	Barb 10-32 x 1/16".....	022-059	1
8	Spring Slider.....	106-311	1	18	Nut, Hex, Jam 9/16-18, Nylon Insert.....	002-011	1	28	1/8" Supply Line, Black.....	115-028	11
9	Rod.....	106-327	1	19	Collar, w/Shoulder, Brake, Flex.....	106-338	1	29	Socket Set Screw, 10-32 x 1/4".....	005-035	1
10	Spring.....	008-019	1	20	Brake Pad.....	106-313	8				

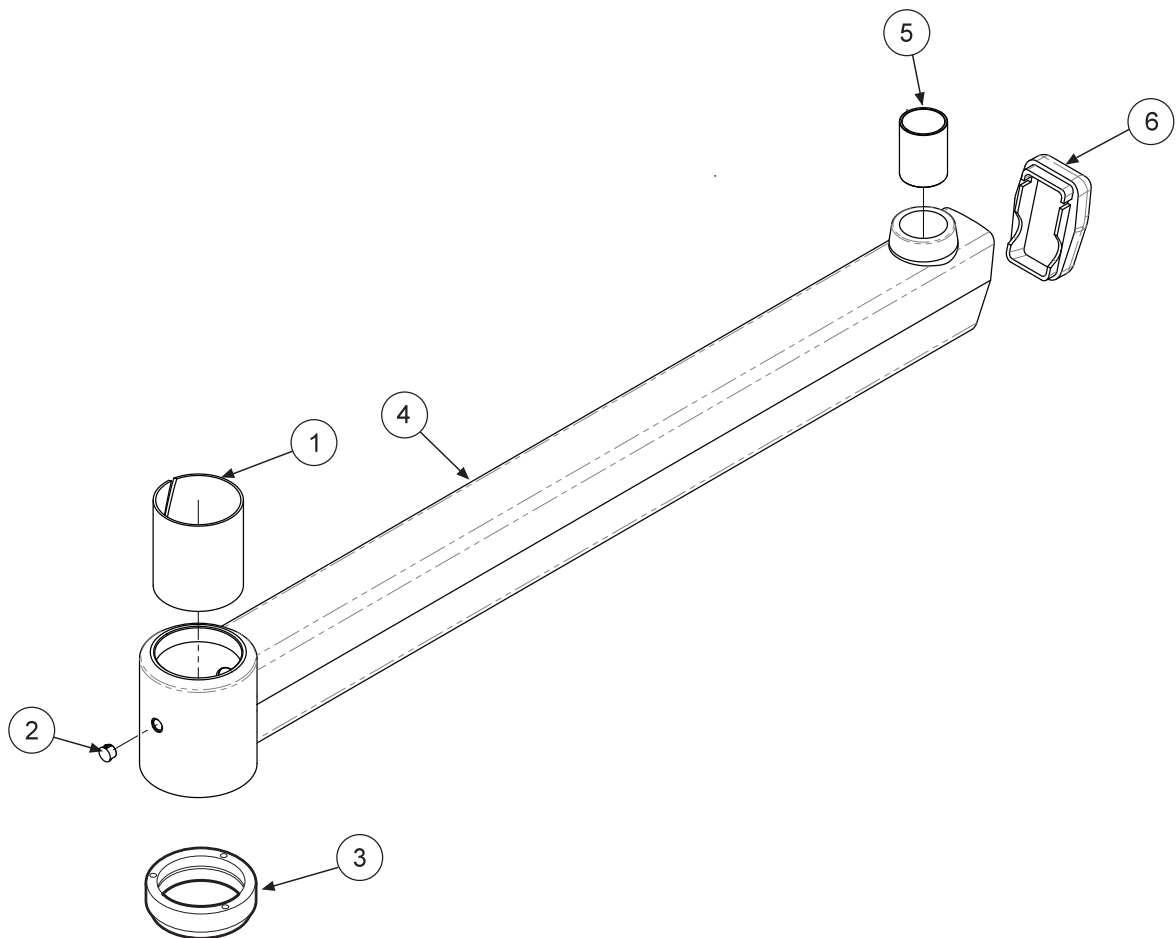

ITEM	PART DESCRIPTION	PART NUMBER	QTY
1	Plug	010-039	1
2	Bushing	013-007	2
3	Post Mount Ring	106-303	1
4	Rigid Arm Housing.....	106-348	1
5	Bronze Bushing	013-019	1
6	End Cap.....	106-326	1

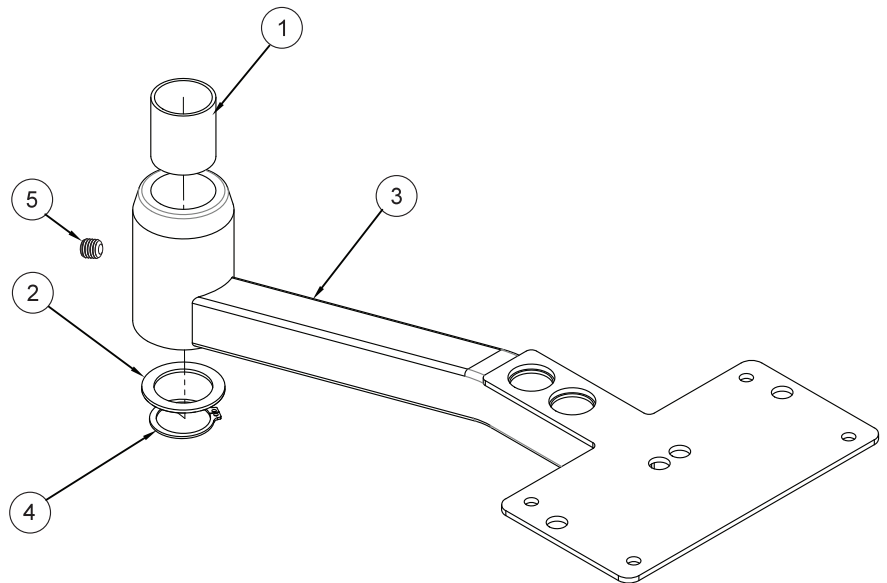

ITEM	PART DESCRIPTION	PART NUMBER	QTY
1	Plug	010-039	1
2	Washer.....	003-038	1
3	Euro Control Mt. Sub Assembly.....	106-357	1
4	Rigid Arm Housing.....	106-348	1
5	Set Screw	005-007	1

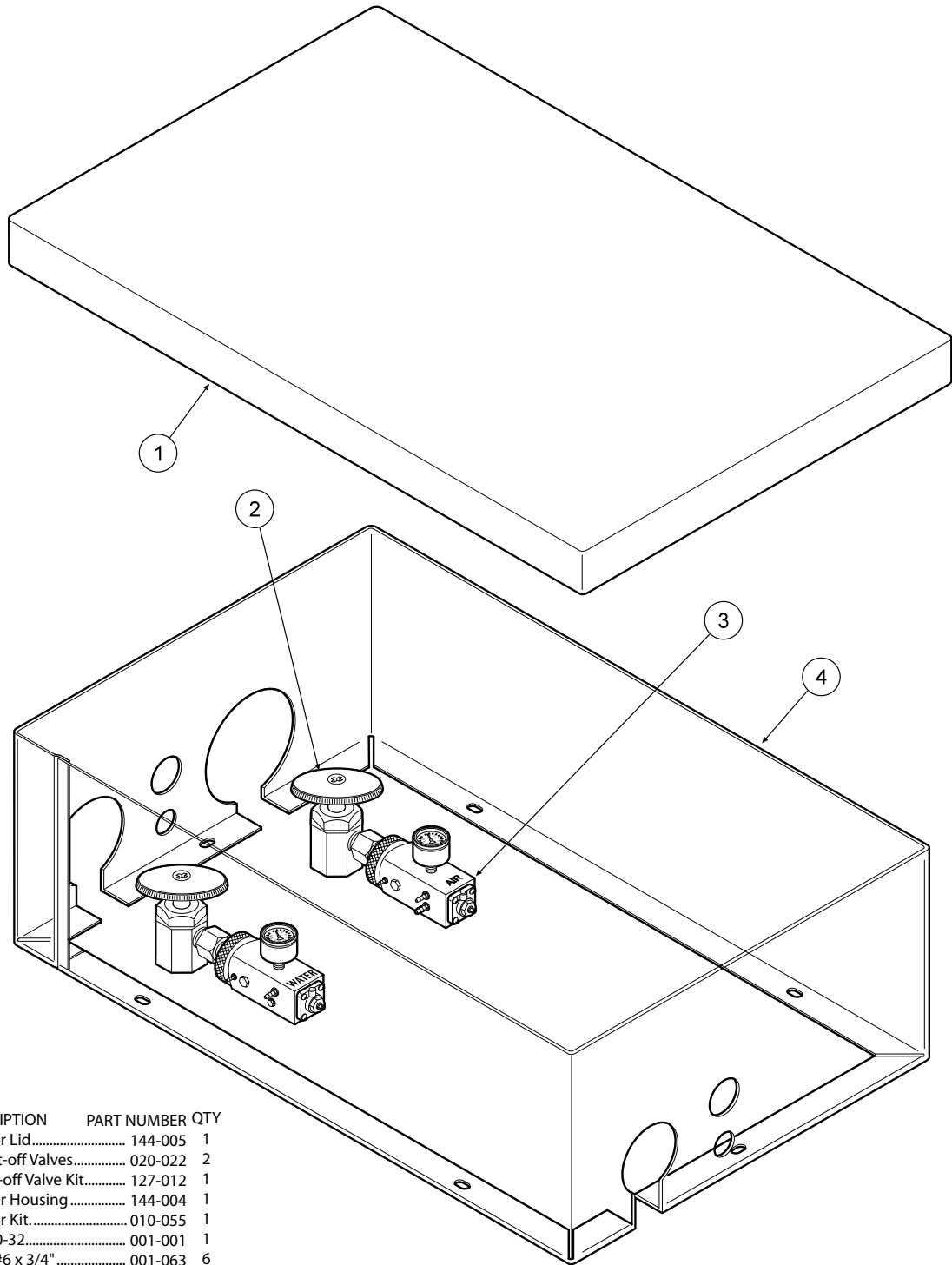

ITEM	PART DESCRIPTION	PART NUMBER	QTY
1	Utility Center Lid.....	144-005	1
2	Manual Shut-off Valves.....	020-022	2
3	Master Shut-off Valve Kit.....	127-012	1
4	Utility Center Housing.....	144-004	1
	Utility Center Kit.....	010-055	1
	Plug, 10-32.....	001-001	1
	Screw, #6 x 3/4".....	001-063	6
	Plastic Washer, 1/4".....	003-001	2
	Plug, 3/4".....	010-005	2
	Plug, 1-3/8".....	010-008	1
	Plug, 1/2".....	010-013	1
	Plug, 1-1/2".....	010-015	1
	Plug, 2-1/4".....	010-017	1
	Plug, 13/16".....	010-016	2
	Barb, 10-32 x 1/16".....	022-009	1
	Barb, 10-32 x 1/8".....	022-010	1
	Ferrule, 1/8".....	117-007	4

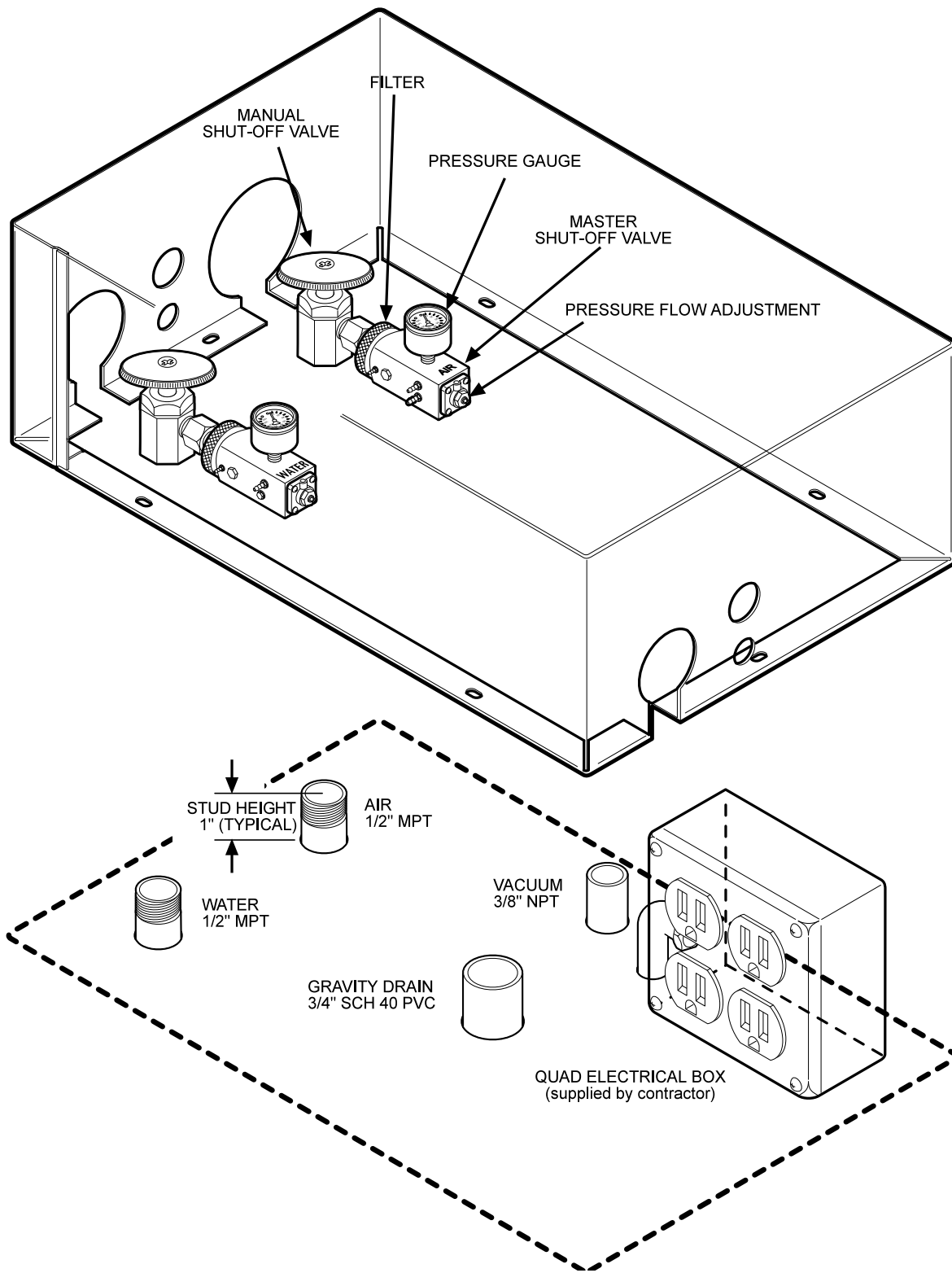

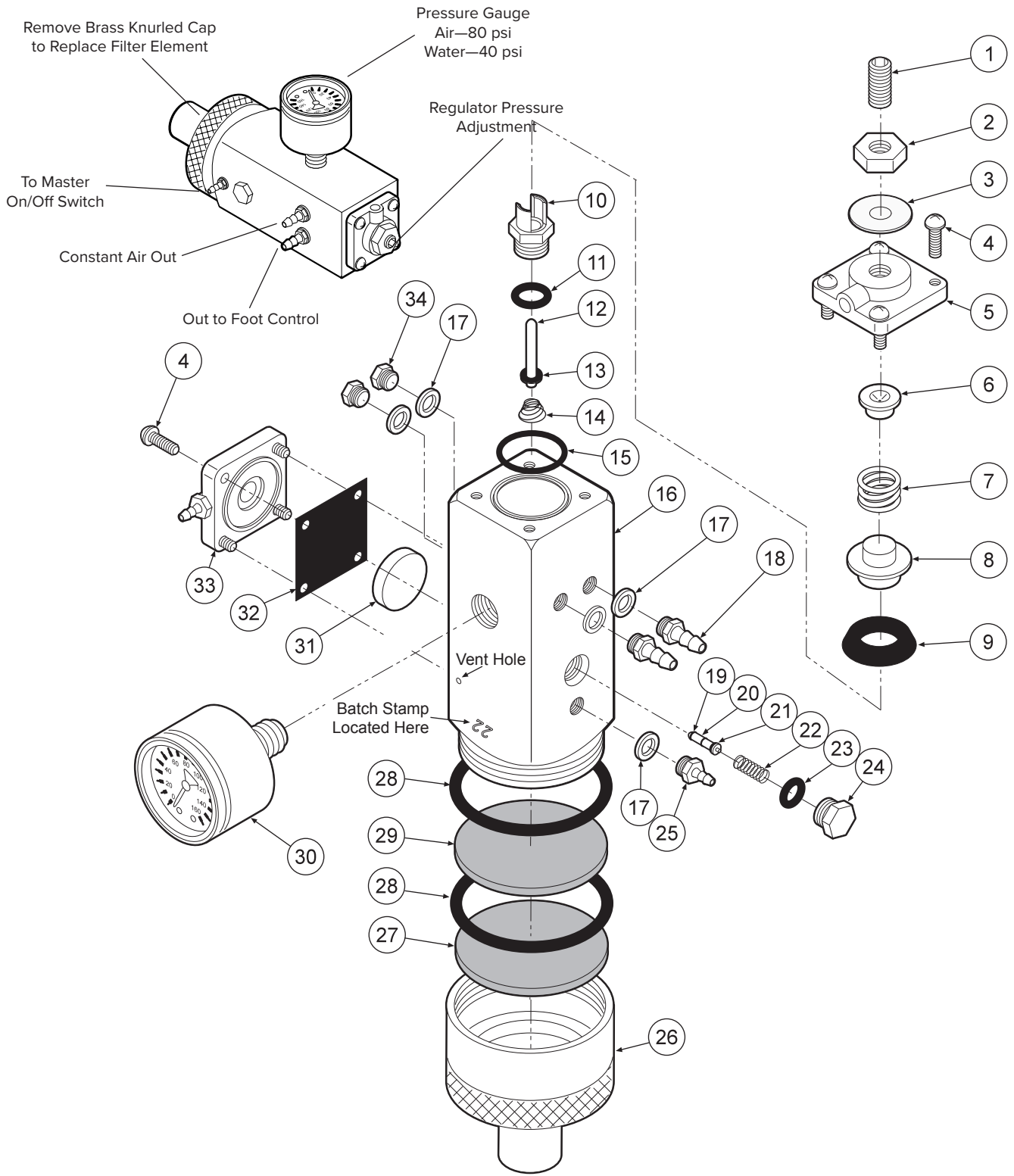

ITEM	PART DESCRIPTION	PART NUMBER	QTY	ITEM	PART DESCRIPTION	PART NUMBER	QTY	ITEM	PART DESCRIPTION	PART NUMBER	QTY
1	Set Screw, 1/4-20 x 5/8"	005-024	1	13	O-Ring, 004	017-104	1	24	Plug	020-026	1
2	Jam Nut, 1/4-20	002-006	1	14	Spring	008-028	1	25	Barb, 10-32 x 1/16"	022-009	1
3	Washer	003-015	1	15	O-Ring	017-018	1	26	Cap Inlet	127-041	1
4	Screw, 6-32 x 3/8"	001-041	8	16	Body	127-040	1	27	Filter Element, 100 Micron	119-005	1
5	Cap	127-033	1	17	Plastic Washer, 1/4"	003-001	5	28	O-Ring, 018	017-022	2
6	Spring Seat	127-043	1	18	Barb, 10-32 x 1/8"	022-010	2	29	Filter Element, 35 Micron	119-004	1
7	Spring	008-008	2	19	O-Ring, 001	017-501	2	30	Gauge	026-001	1
8	Cup Seat	127-044	1	20	Stem	127-045	1	31	Piston	123-014	1
9	Cup Seal	017-200	4	21	O-Ring, 003	017-103	1	32	Gasket	127-031	1
10	Seat	127-026	3	22	Spring	008-040	1	33	Cap	123-030	1
11	O-Ring, 008	017-008	2	23	O-Ring, 007	017-007	1	34	Plug	001-001	2
12	Stem	127-024	1								

Remove Brass Knurled Cap to Replace Filter Element

Pressure Gauge
Air—80 psi
Water—40 psi

Water Out

Regulator Pressure Adjustment

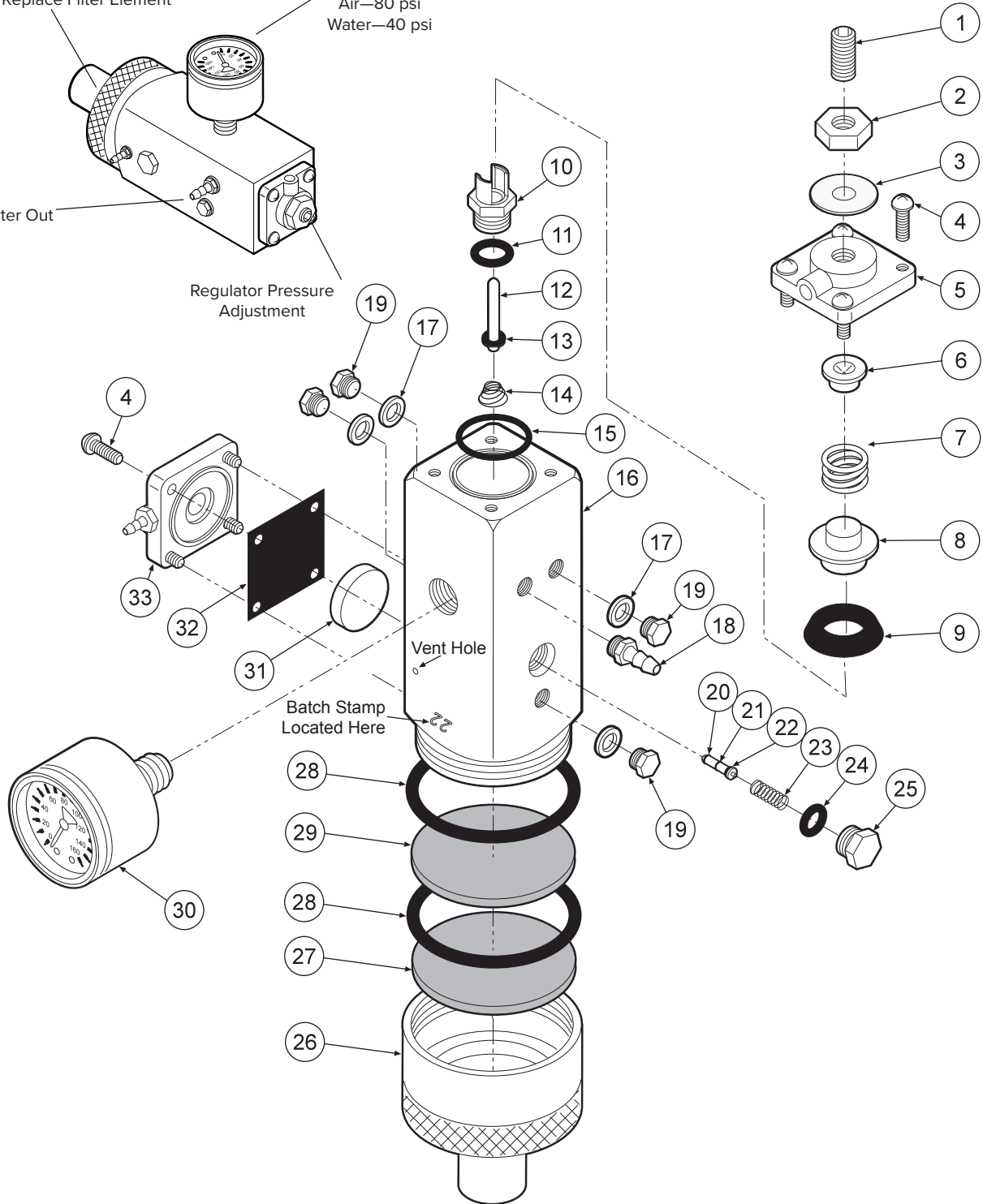

ITEM	PART DESCRIPTION	PART NUMBER	QTY	ITEM	PART DESCRIPTION	PART NUMBER	QTY	ITEM	PART DESCRIPTION	PART NUMBER	QTY
1	Set Screw, 1/4"-20 x 5/8"	005-024	1	12	Stem	127-024	1	23	Spring	008-040	1
2	Jam Nut, 1/4"-20	002-006	1	13	O-Ring, 004	017-104	1	24	O-Ring, 007	017-007	1
3	Washer	003-015	1	14	Spring	008-028	1	25	Plug	020-026	1
4	Screw, 6-32 x 3/8"	001-041	8	15	O-Ring	017-018	1	26	Cap Inlet	127-041	1
5	Cap	127-023	1	16	Body	127-040	1	27	Filter Element, 100 Micron	119-005	1
6	Spring Seat	127-043	1	17	Plastic Washer, 1/4"	003-001	1	28	O-Ring, 018	017-022	2
7	Spring	008-008	1	18	Barb, 10-32 x 1/8"	022-010	1	29	Filter Element, 35 Micron	119-004	1
8	Cup Seat	127-044	1	19	Plug	001-001	4	30	Gauge	126-001	1
9	Cup Seal	017-200	1	20	O-Ring, 001	017-501	2	31	Piston	123-014	1
10	Seat	127-026	1	21	Stem	127-045	1	32	Gasket	127-031	1
11	O-Ring, 008	017-008	1	22	O-Ring, 003	017-103	1	33	Cap	123-012	1

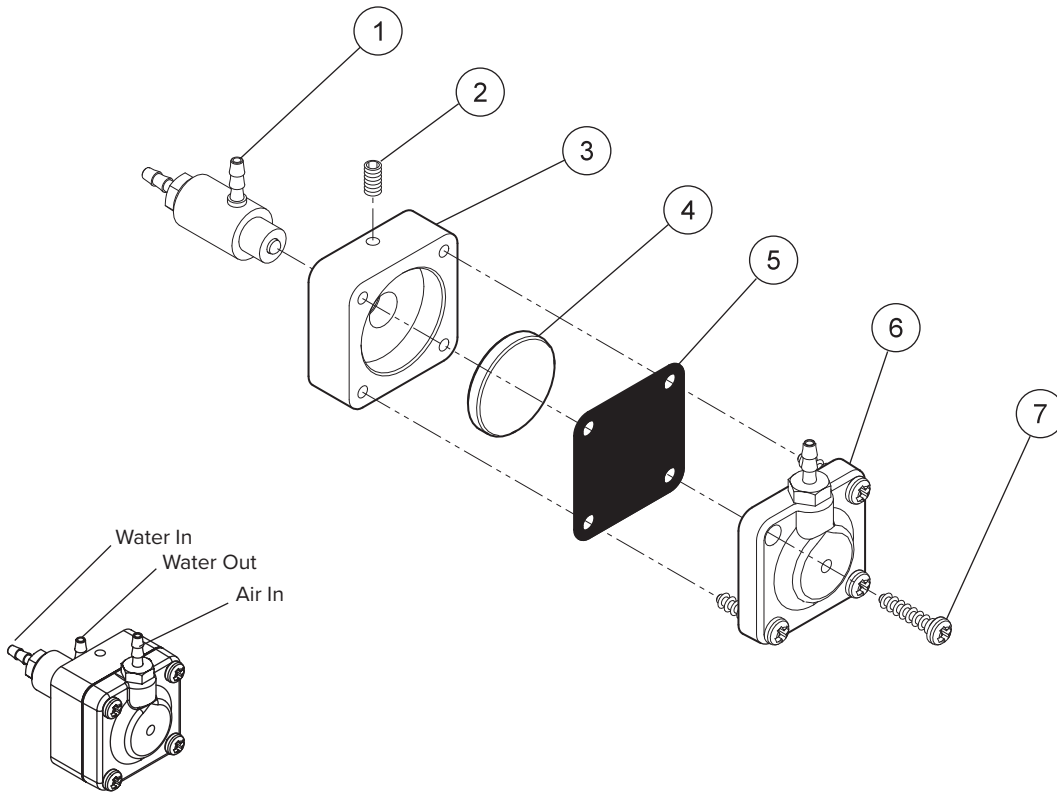
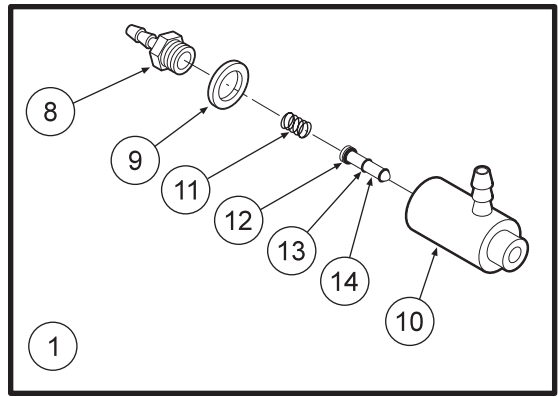

Water Relay Valve 123-000

ITEM	PART DESCRIPTION	PART NUMBER	QTY
1	Cartridge Body Assembly.....	123-018	1
2	Set Screw, 4-40 x 5/8".....	005-028	1
3	Body.....	123-013	1
4	Piston.....	123-014	1
5	Diaphragm.....	127-031	1
6	Cap.....	123-012	1
7	Screw, #6 x 1/2".....	001-267	4
8	Barb, 10-32 x 1/16".....	022-009	1
9	Plastic Washer, 1/4".....	003-001	1
10	Valve Body.....	123-017	1
11	Spring.....	008-011	1
12	O-Ring, 002.....	017-502	1
13	O-Ring, 001.....	017-501	2
14	Stem.....	123-015	1



CAUTION

When adjusting the handpiece pressure, do not over-tighten the screws. Damage may result.

The automatic control block is the control center for your dental unit.

Individual handpiece pressure adjustments are located on the autoblock. To adjust the pressure to each handpiece:

- a. Turn adjustment screw *clockwise* to decrease the handpiece pressure.
- b. Turn adjustment screw *counter-clockwise* to increase the handpiece pressure.

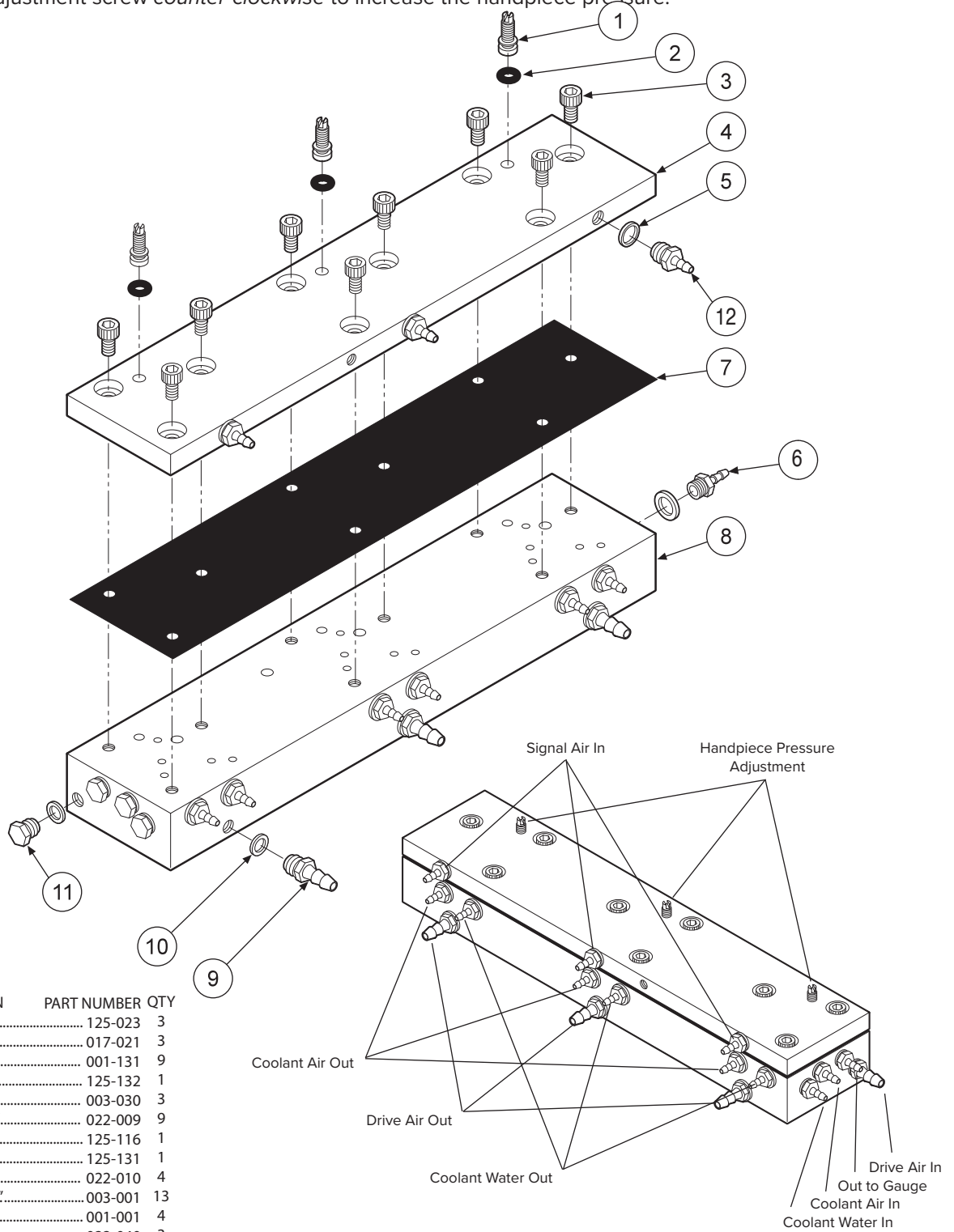

ITEM	PART DESCRIPTION	PART NUMBER	QTY
1	Adjusting Stem.....	125-023	3
2	O-Ring, 021	017-021	3
3	Screw, 6-32 x 1/4".....	001-131	9
4	Cap.	125-132	1
5	Plastic Washer.	003-030	3
6	Barb, 10-32 x 1/16".....	022-009	9
7	Diaphragm	125-116	1
8	Body	125-131	1
9	Barb, 10-32 x 1/8".....	022-010	4
10	Plastic Washer, 1/4".....	003-001	13
11	Plug, 10-32	001-001	4
12	Barb, 8-32 x 1/16".....	022-040	3

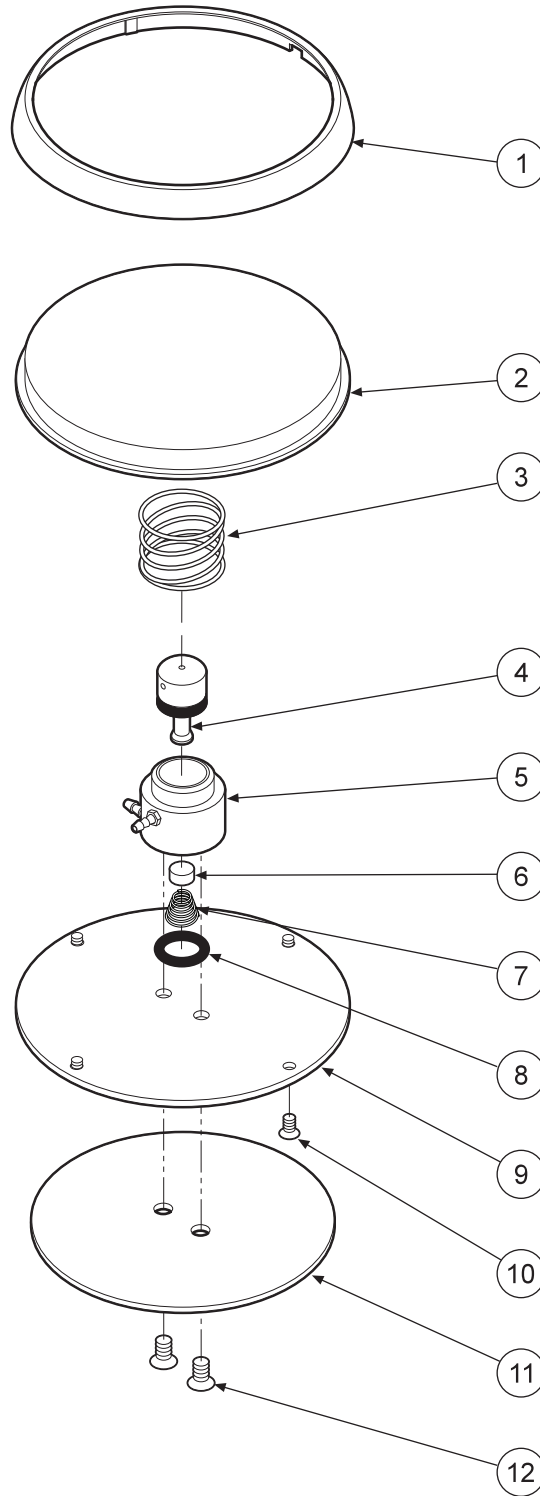

ITEM	PART DESCRIPTION	PART NUMBER	QTY
1	Ring.....	126-202	1
2	Cover.....	126-201	1
3	Spring.....	008-005	1
4	Stem (Includes 017-012 o-ring).....	126-005	1
5	Body.....	126-004	1
6	Poppet.....	126-006	1
7	Spring.....	008-006	1
8	O-Ring, 013.....	017-013	1
9	Baseplate.....	126-003	1
10	Screw, 4-40 x 1/4".....	001-005	4
11	Rubber Pad.....	126-007	1
12	Screw, 6-32 x 1/4".....	001-004	2

FOOT CONTROL
126-200



Euro 3 Handpiece Automatic control S-6300

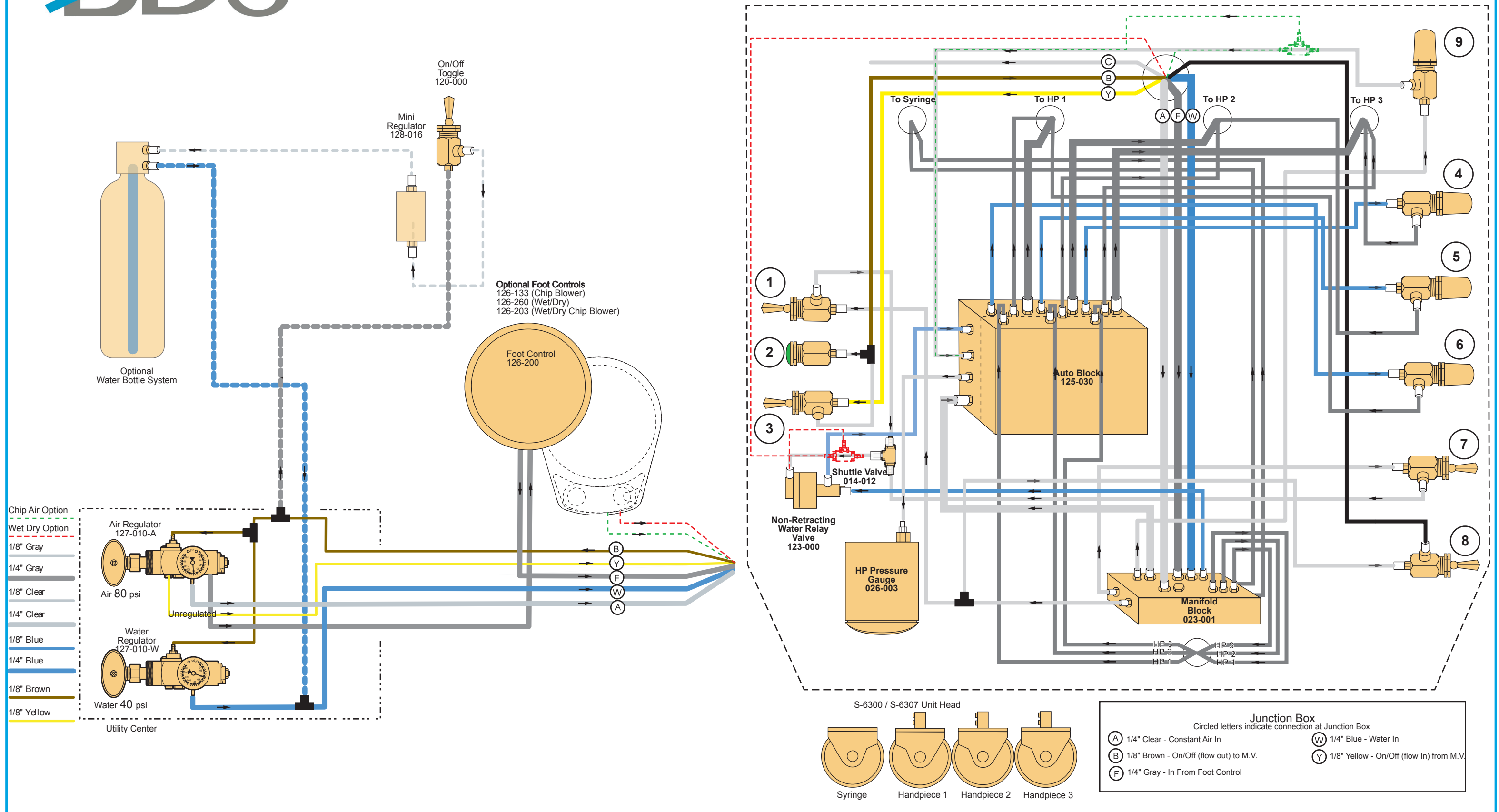

WARRANTY

BDS warrants its product to be free of defects in material and workmanship for SEVEN FULL YEARS from the date of purchase on all units. Auto-blocks and standard foot controls are covered by a LIFETIME warranty when factory installed as part of a complete dental system. Upholstery has a TWO YEAR warranty and does not cover normal wear, stains, cuts or tears. Our LED lights have a FIVE year Warranty and our halogen light has a ONE year Warranty. Operatory chair motors feature a TEN year warranty. All warranty is limited to repair or replacement by BDS. Products returned to the factory and determined to be defective will be repaired or replaced free of charge at discretion of BDS. The warranty does not cover light bulbs, electrical components and trimmed or installed tubing. BDS reserves the right to void all warranties if any product is installed by other than an authorized technician. BDS' warranty does not cover damage to any surface finish, including but not limited to, discoloration or abrasion from cleaners, disinfectants or light sources. No claim for labor or consequential damages will be allowed. Return items must include a copy of the invoice or packing slip as proof of purchase.

**Beaverstate Dental Inc.
115 S. Elliott Rd.
Newberg, OR 97132
800-237-2303
503-538-8756
503-538-2845 Fax
www.beaverstatedental.com**
