



Service Manual

A-5221 / A-5222

Telescoping Arm System with Vacuum
Package HVE, S/E and No Syringe

A-5221 / A-5222

Installation

1. Place the shipping carton in the desired location. Remove the vacuum system with telescoping arm from the shipping carton.
2. Mount the post clamp to the post at the desired height.
3. Insert the rigid arm into the post clamp.
4. Place the HVE and S/E valves in their holders and connect the tubing to the ports on the vacuum cannister. Connect the drain and syringe tubing to the appropriate connections.
6. Place the syringe in its holder.

Final Adjustments

- Check air pressure, adjust to 80 psi if necessary.
- Check water pressure, adjust to 40 psi if necessary.
- Check vacuum cannister for solids screen.
- Test HVE and S/E valves for proper function.
- Test syringe for proper pressure and function.

Operation

1. Insure that the central vacuum system is turned on and air and water pressure are at the proper setting.
2. Lift the vacuum valve out of the holder and push the lever down towards the base of the valve to allow vacuum to begin.

Cleaning

1. Separate valve from tubing at the quick disconnect swivel by pulling them apart. Remove the lever and the spool and clean in an ultrasonic cleaner.
2. Rinse thoroughly before putting components into autoclave.
3. Lubricate O-Rings on the spool with a silicone based lubricant and reassembly.

Autoclavable HVE and S/E Valves

Maintenance Autoclavable vacuum valves may be autoclaved by steam autoclave or a chemical vapor. Due to the tight clearances and hardness of the anodized surfaces, the valve spool can become jammed or seize in the valve if it is sterilized while contaminated with debris.

Valves can be quickly disassembled for cleaning.

1. Pry one side of the lever and flip it off of the valve. For saliva ejector valves, remove the tip also.
2. Push out the valve spool and clean all the disassembled parts in an ultrasonic cleaner daily. Rinse thoroughly before putting into autoclave.
3. Lubricate the O-Rings on the spool with a silicone based lubricant before reassembly.

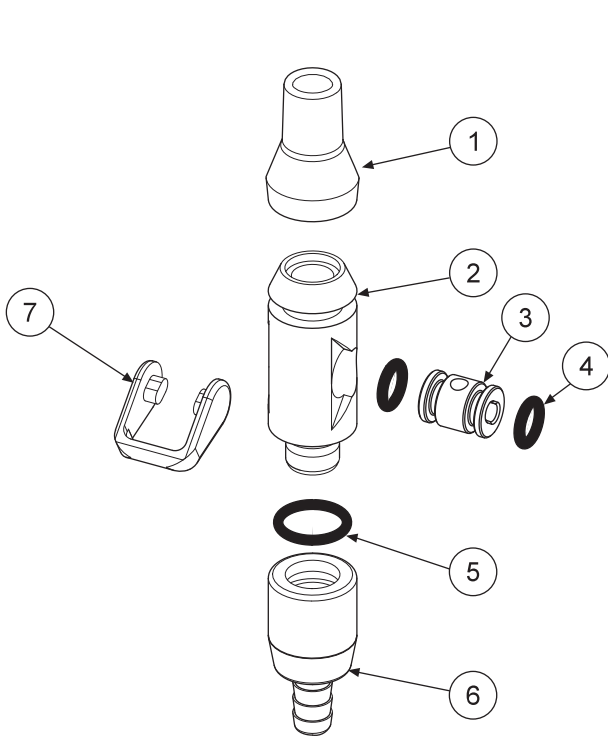

ITEM	PART DESCRIPTION	PART NUMBER	QTY
1	Tip.....	112-174	1
2	Body.....	112-276	1
3	Spool.....	112-278	1
4	O-Ring #10.....	017-110	2
5	O-Ring, #12.....	017-012	1
6	Swivel.....	112-177	1
7	Lever.....	112-181	1

AUTOCLAVABLE S/E LEVER VALVE
112-280

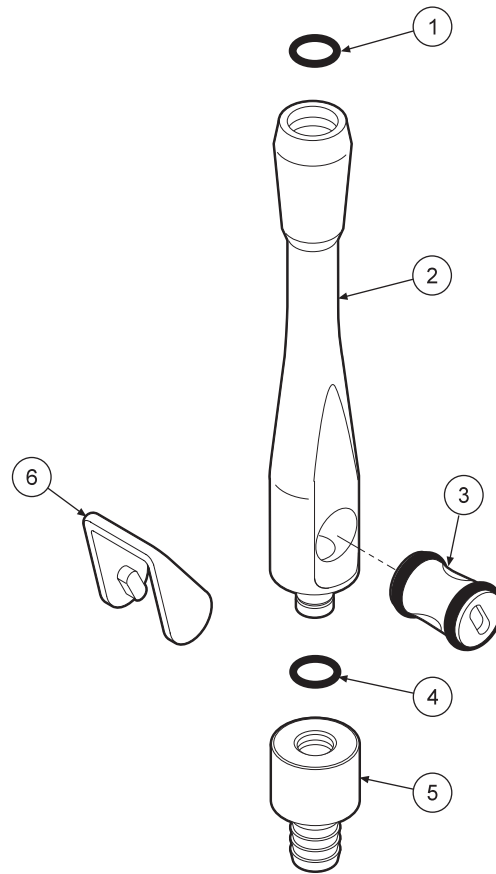

ITEM	PART DESCRIPTION	PART NUMBER	QTY
1	O-Ring, #13.....	017-113	3
2	Body, Chrome.....	112-272	1
3	Spool, Chrome.....	112-268	1
4	O-Ring, #13.....	017-013	1
5	Swivel.....	112-170	1
6	Lever.....	112-169	1

AUTOCLAVABLE UNIVERSAL HVE VALVE
112-263

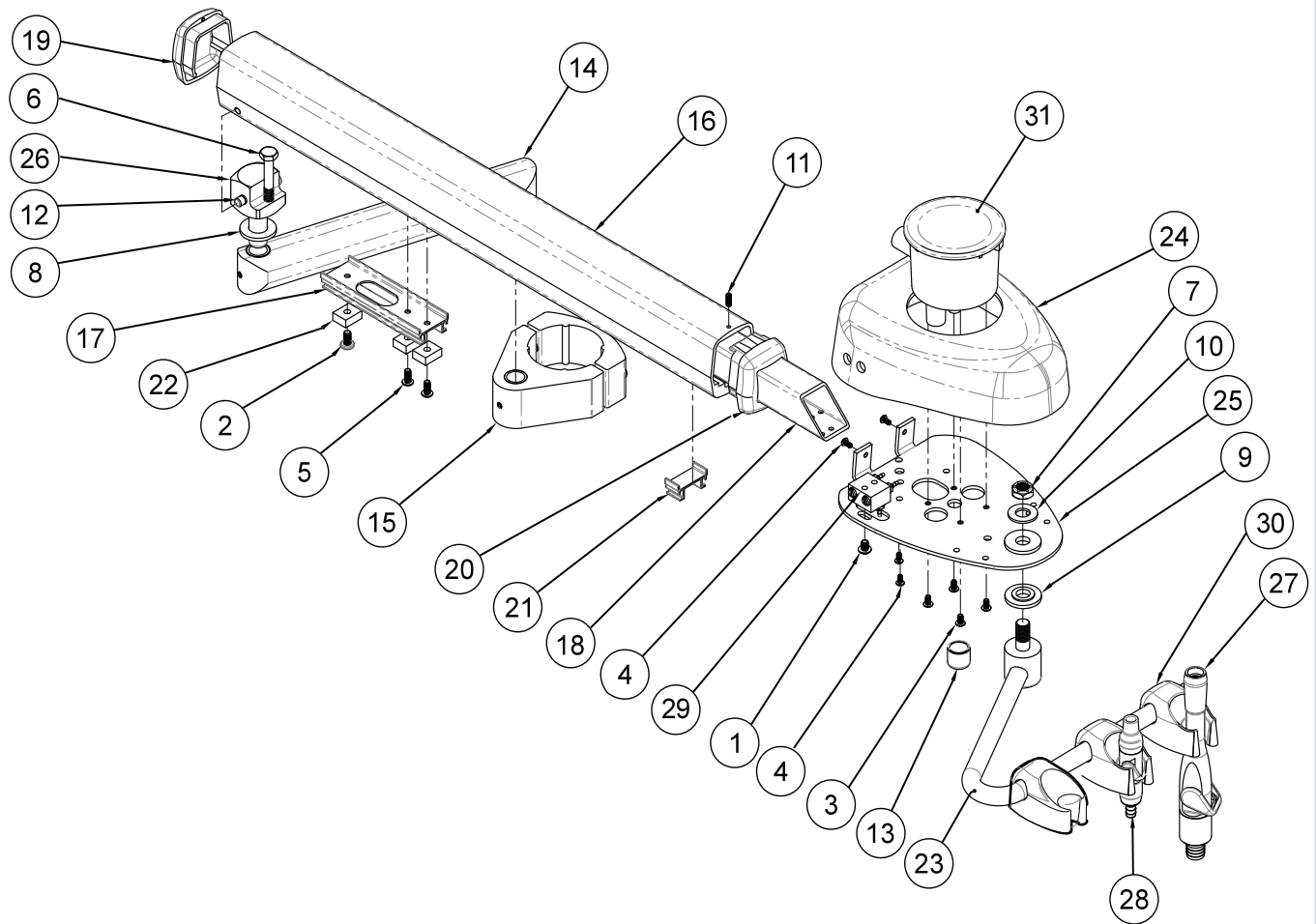

ITEM	PART DESCRIPTION	PART NUMBER	QTY	ITEM	PART DESCRIPTION	PART NUMBER	QTY
1	Screw, 10-32 x 1/4"	001-032	1	17	Telescoping Arm Slide	102-214	1
2	Screw, 10-32 x 3/8"	001-070	1	18	Telescoping Arm Tube	105-216	3
3	Screw, 6-32 x 1/4"	001-133	1	19	Telescoping Arm End Cap	105-217	6
4	Screw, 8-32 x .25	001-149	2	20	105-218 With Modified Tab	105-218	6
5	Screw, 8-32 x .375	001-161	7	21	Telescoping Arm Front Slide Guide	105-219	2
6	Carriage Bolt 1/4-20 x 1-3/4"	001-446	1	22	Telescoping Arm Slider Block	105-220	1
7	Lock Nut 3/8-24	002-002	1	23	7" Holder Bar Assembly	105-223	1
8	Washer 1/2"	003-006	1	24	Vacuum Cover	105-230	1
9	Washer Shoulder S-5325	003-013	10ft.	25	Vacuum Chassi	105-232	1
10	Washer 3/8"	003-025	1	26	Telescoping Arm Pivot	105-258	2
11	Screw, 6-32 x 3/8"	005-018	1	27	Universal HVE Valve	112-263	1
12	Mechanical Flex Housing pin	009-013	1	28	Autoclavable S/E Valve	112-280	1
13	HVE Port Cap	010-009	1	29	Syringe Adjustment Block	113-026	1
14	8" Folding Arm Section	015-039	1	30	Syringe Holder	141-200	3
15	2" Post Mount Clamp	105-051	2	31	Vacuum Canister	131-036	1
16	Telescoping Arm Slide Housing	105-212	1				

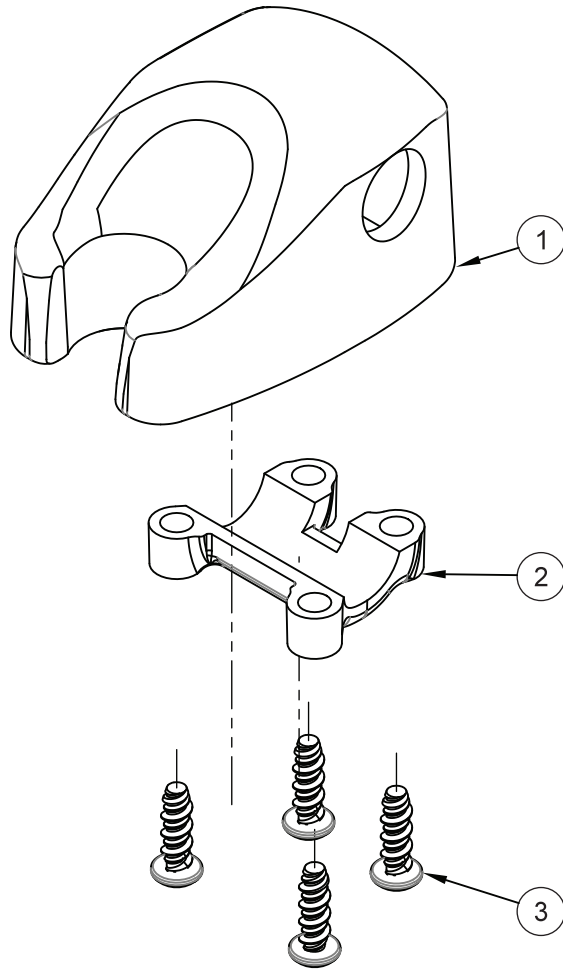

ITEM	PART DESCRIPTION	PART NUMBER	QTY
1	Molded Body.....	141-201	1
2	Clamp	122-204	1
3	Screw, 8-32 x 1/2".....	001-267	4

WARRANTY

BDS warrants its product to be free of defects in material and workmanship for SEVEN FULL YEARS from the date of purchase on all units. Auto-blocks and standard foot controls are covered by a LIFETIME warranty when factory installed as part of a complete dental system. Upholstery has a TWO YEAR warranty and does not cover normal wear, stains, cuts or tears. Our LED lights have a FIVE year Warranty and our halogen light has a ONE year Warranty. Operatory chair motors feature a TEN year warranty. All warranty is limited to repair or replacement by BDS. Products returned to the factory and determined to be defective will be repaired or replaced free of charge at discretion of BDS. The warranty does not cover light bulbs, electrical components and trimmed or installed tubing. BDS reserves the right to void all warranties if any product is installed by other than an authorized technician. BDS' warranty does not cover damage to any surface finish, including but not limited to, discoloration or abrasion from cleaners, disinfectants or light sources. No claim for labor or consequential damages will be allowed. Return items must include a copy of the invoice or packing slip as proof of purchase.

**Beaverstate Dental Inc.
115 S. Elliott Rd.
Newberg, OR 97132
800-237-2303
503-538-8756
503-538-2845 Fax
www.beaverstatedental.com**
