



Service Manual
A-5210
Telescoping Arm
System with Vacuum Package

Installation

1. Place the shipping carton in the desired location. Remove the vacuum system with telescoping arm from the shipping carton.
2. Mount the post clamp to the post at the desired height.
3. Insert the rigid arm into the post clamp.
4. Place the HVE and S/E valves in their holders and connect the tubing to the ports on the vacuum cannister. Connect the drain and syringe tubing to the appropriate connections.
6. Place the syringe in its holder.

Final Adjustments

Check air pressure, adjust to 80 psi if necessary.
Check water pressure, adjust to 40 psi if necessary.
Check vacuum cannister for solids screen.
Test HVE and S/E valves for proper function.
Test syringe for proper pressure and function.

Operation

1. Insure that the central vacuum system is turned on and air and water pressure are at the proper setting.
2. Lift the vacuum valve out of the holder and push the lever down towards the base of the valve to allow vacuum to begin.

Cleaning

1. Separate valve from tubing at the quick disconnect swivel by pulling them apart. Remove the lever and the spool and clean in an ultrasonic cleaner.
2. Rinse thoroughly before putting components into autoclave.
3. Lubricate O-Rings on the spool only with a silicone based lubricant and reassemble.

Autoclavable HVE & S/E Valves

Maintenance Autoclavable vacuum valves may be autoclaved by steam autoclave or a chemical vapor. Due to the tight clearances and hardness of the anodized surfaces, the valve spool can become jammed or seize in the valve if it is sterilized while contaminated with debris.

Valves can be quickly disassembled for cleaning.

1. Pry one side of the lever and flip it off of the valve. For saliva ejector valves, remove the tip also.
2. Push out the valve spool and clean all the disassembled parts in an ultrasonic cleaner daily. Rinse thoroughly before putting into autoclave.
3. Lubricate the O-Rings on the spool with a silicone based lubricant before reassembly.

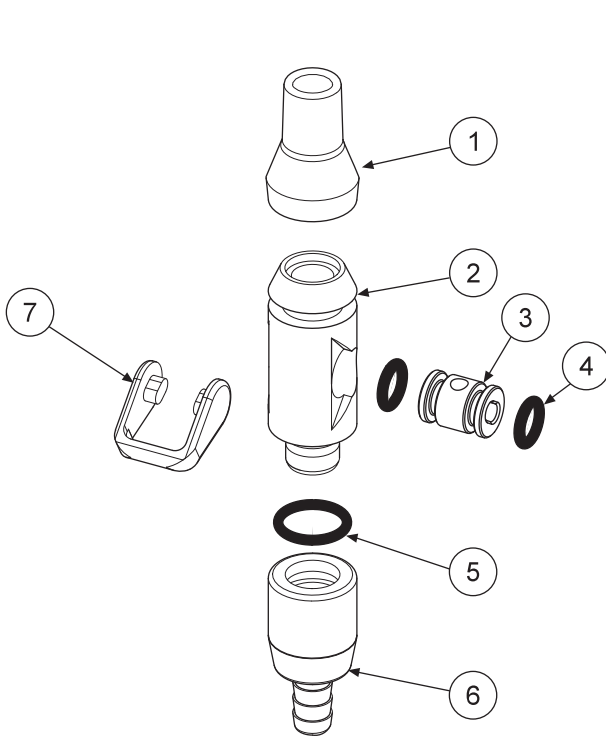

ITEM	PART DESCRIPTION	PART NUMBER	QTY
1	Tip.....	112-174	1
2	Body.....	112-276	1
3	Spool.....	112-278	1
4	O-Ring #10.....	017-110	2
5	O-Ring, #12.....	017-012	1
6	Swivel.....	112-177	1
7	Lever.....	112-181	1

**AUTOCLAVABLE S/E LEVER VALVE,
CHROME**

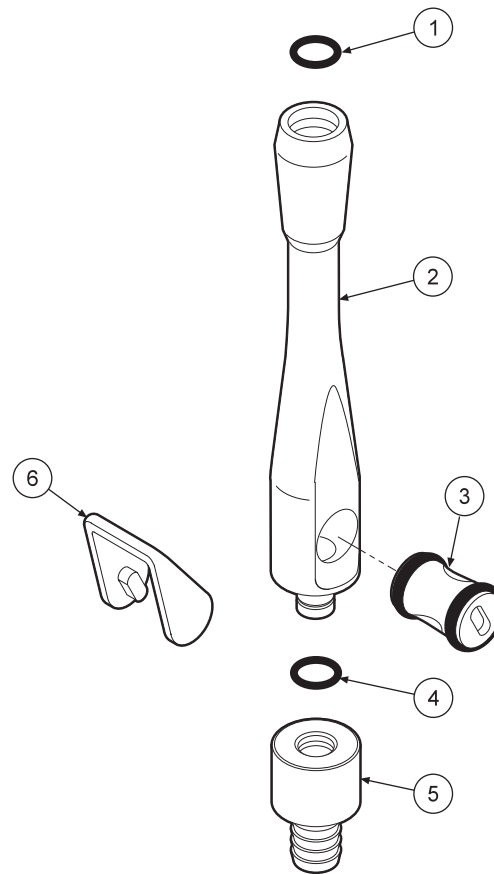

ITEM	PART DESCRIPTION	PART NUMBER	QTY
1	O-Ring, #13.....	017-113	3
2	Body, Chrome.....	112-272	1
3	Spool, Chrome.....	112-268	1
4	O-Ring, #13.....	017-013	1
5	Swivel.....	112-170	1
6	Lever.....	112-169	1

**AUTOCLAVABLE UNIVERSAL HVE VALVE
112-263**

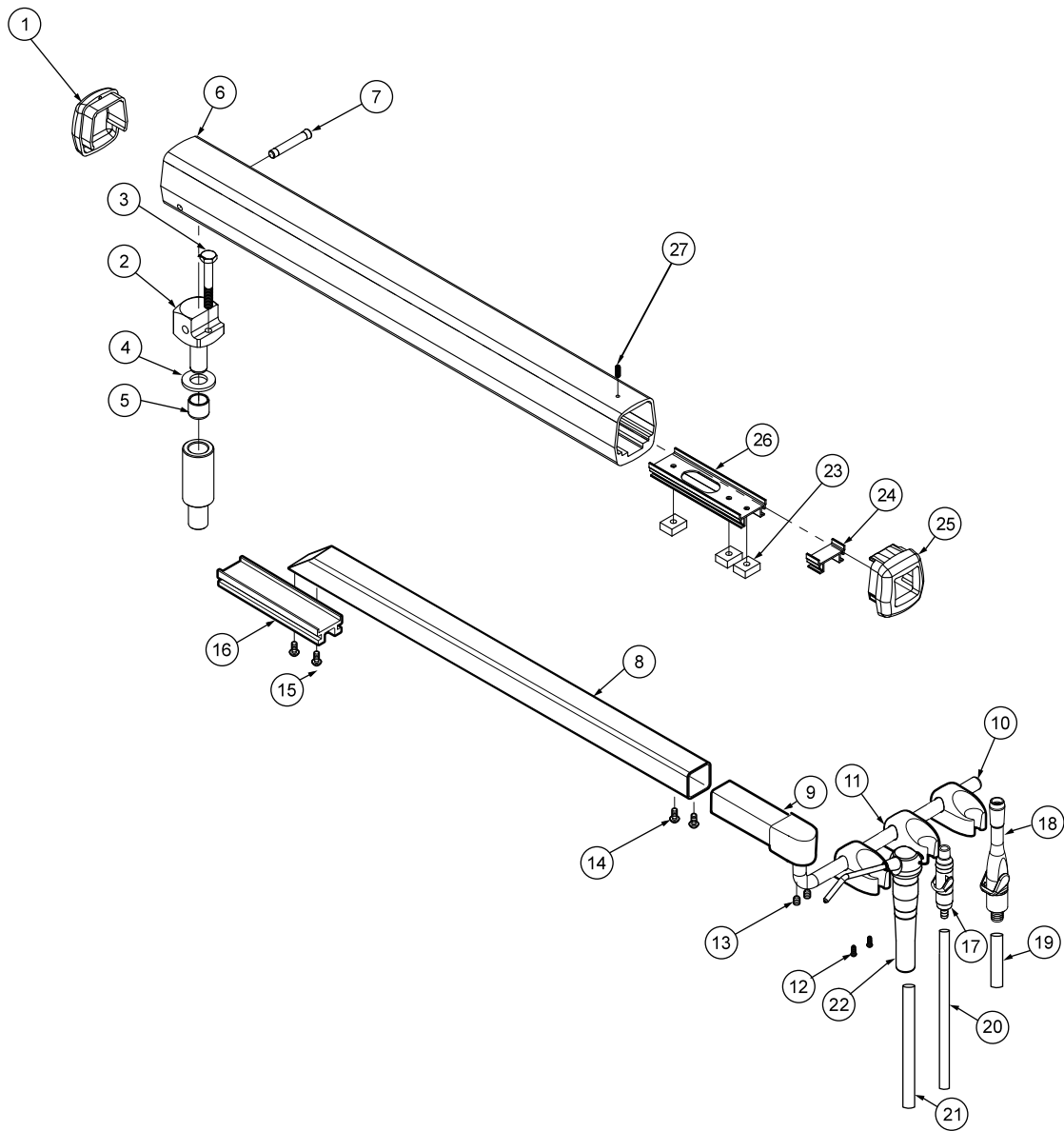

ITEM	PART DESCRIPTION	PART NUMBER	QTY	ITEM	PART DESCRIPTION	PART NUMBER	QTY	ITEM	PART DESCRIPTION	PART NUMBER	QTY
1	End Cap	105-217	1	10	Holder Bar	105-173	1	19	Asepsis - Flex Tubing, Sterling 1/2"	115-717	10 ft.
2	Knuckle	105-258	1	11	Syringe Holder, Molded	141-200	3	20	S/E Tubing, Sterling 7/32"	115-734	5 ft.
3	Carriage Bolt	001-446	1	12	Screw, #8 x 1/2" Plastite	001-018	8	21	Syringe Tubing	115-764	5 ft.
4	Washer, 1/2"	003-006	1	13	Set Screw, 10-32 x 1/4"	005-026	2	22	Syringe	113-400	1
5	HVE port cap	010-009	1	14	Screw, 8-32 x 1/4"	001-134	2	23	Arm slider block	105-220	3
6	Tele arm housing	105-212	1	15	Screw, 8-32 x 3/8"	001-070	6	24	Guide slide	105-219	1
7	Pin	009-013	1	16	Tube Slide	105-214	1	25	Open end cap	105-218	1
8	Inner Tube	105-216	1	17	S/E Autoclavable	112-280	1	26	Slide	105-214	1
9	Pivoting holder bar block	105-178	1	18	HVE, Universal Autoclavable	112-263	1	27	Screw, 6-32 x 3/8"	005-018	1

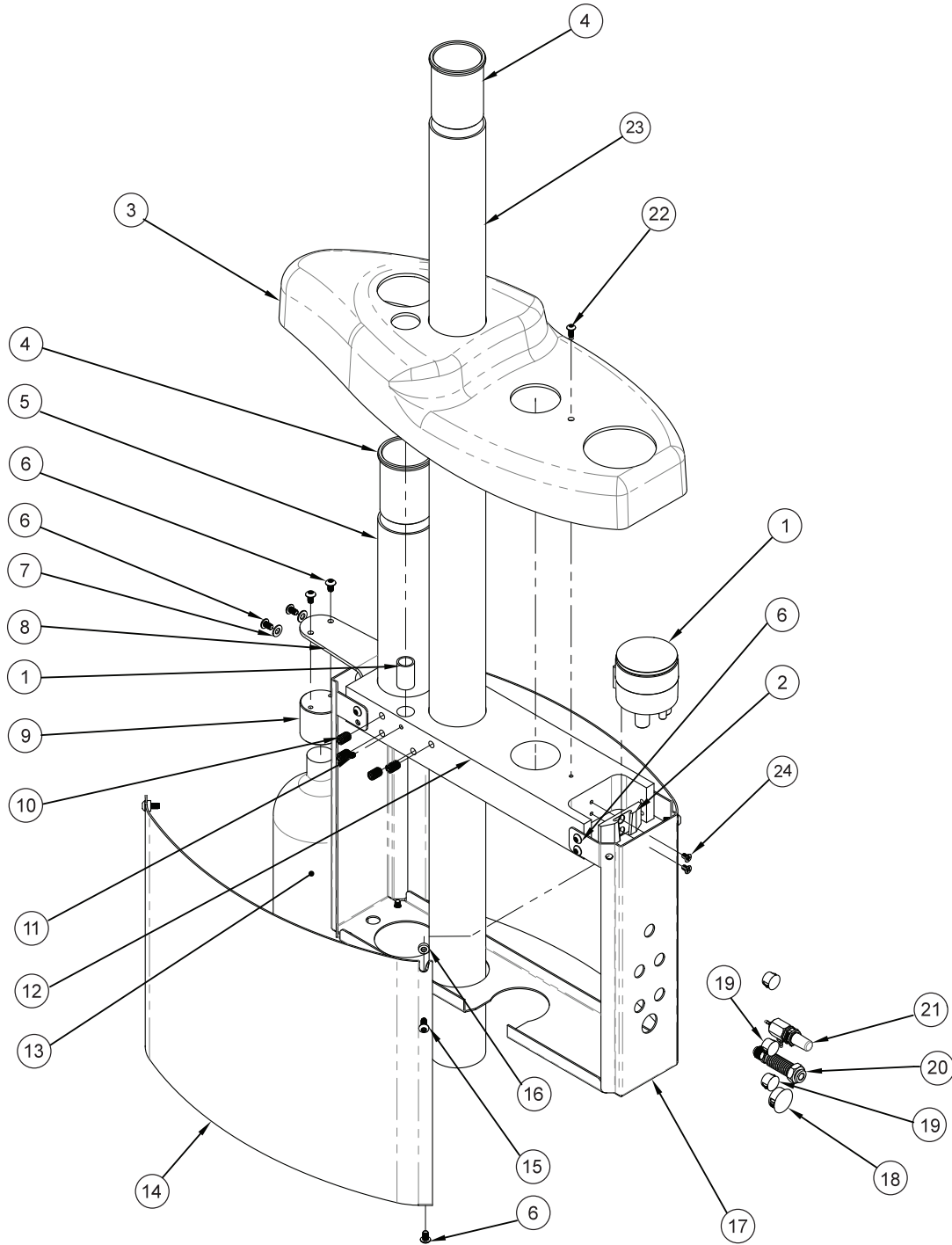

ITEM	PART DESCRIPTION	PART NUMBER	QTY	ITEM	PART DESCRIPTION	PART NUMBER	QTY	ITEM	PART DESCRIPTION	PART NUMBER	QTY
1	Vacuum Canister.....	131-038	1	11	Set Screw, 10-32 x 3/16".....	005-037	1	21	Needle flow valve.....	121-000	1
2	Canister bracket.....	131-021	1	12	Aluminum block.....	145-026	1	22	Screw, 8-32 .375.....	001-161	1
3	Top cover side box.....	145-025	1	13	1 Liter bottle.....	110-041	1	23	40" side box post.....	146-204	1
4	Pelton - crane adapter.....	146-208	2	14	Side Cover.....	145-041	2	24	Screw, 8-32 x 1/4".....	001-003	2
5	Riser post side box.....	144-064	1	15	Screw 10-32 x 50".....	001-171	4				
6	Screw, 10-32 x 5/16".....	001-077	14	16	Washer.....	003-063	4				
7	Washer #10.....	003-024	2	17	Base housing cover.....	145-040	1				
8	Water bottle bracket.....	145-013	1	18	Plug 3/4".....	010-005	1				
9	Pressure head.....	110-007	1	19	Plug 1/2".....	010-013	3				
10	Set screw 5/16"-18 x 1/2".....	005-010	4	20	1/4" Feemale QD.....	024-003	1				

**145-000 SIDE BOX
FOR EVERGREEN OPERATORY PACKAGE**

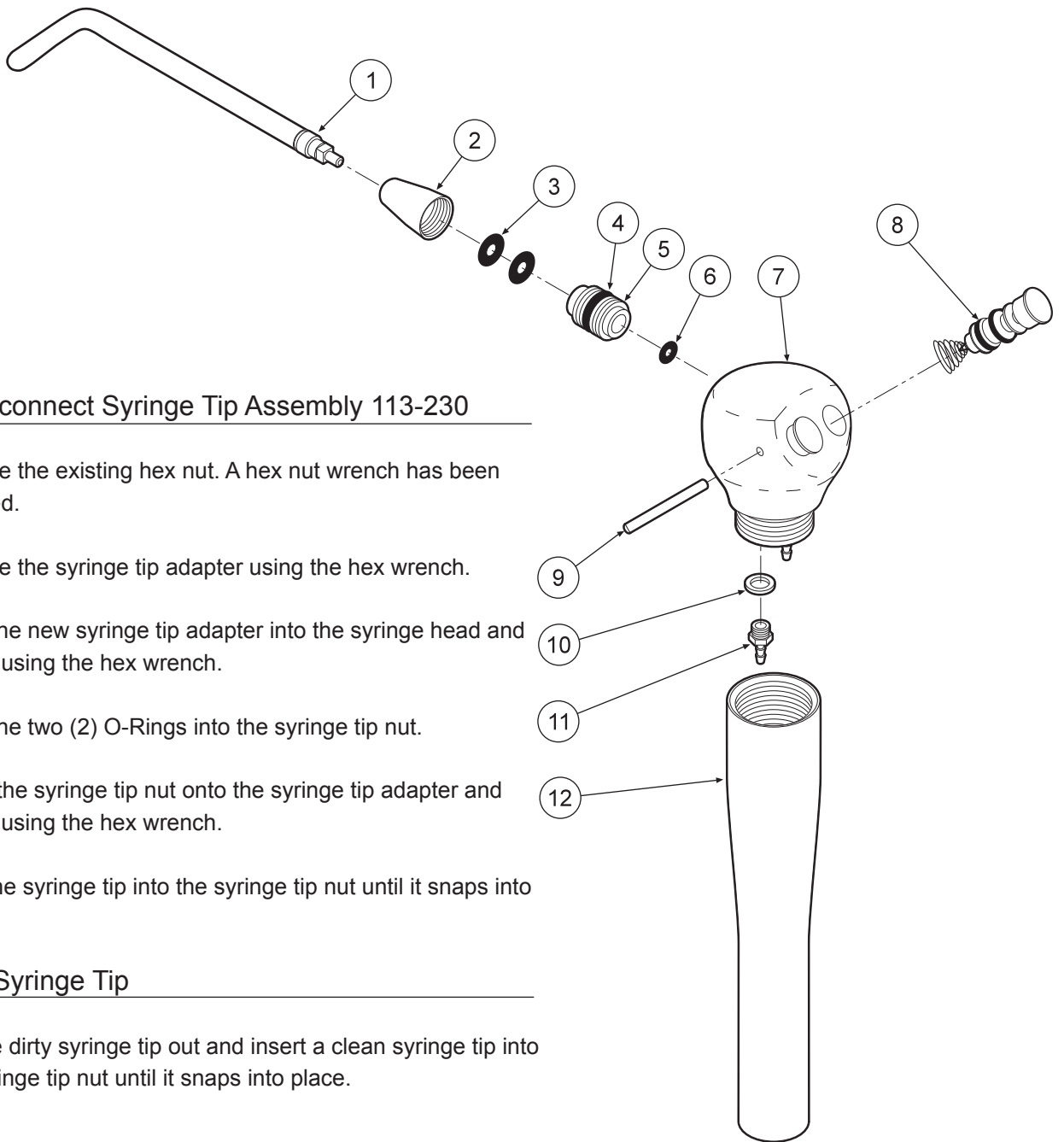

Quick-disconnect Syringe Tip Assembly 113-230

1. Remove the existing hex nut. A hex nut wrench has been provided.
2. Remove the syringe tip adapter using the hex wrench.
3. Insert the new syringe tip adapter into the syringe head and tighten using the hex wrench.
4. Place the two (2) O-Rings into the syringe tip nut.
5. Screw the syringe tip nut onto the syringe tip adapter and tighten using the hex wrench.
6. Push the syringe tip into the syringe tip nut until it snaps into place.

Replace Syringe Tip

1. Pull the dirty syringe tip out and insert a clean syringe tip into the syringe tip nut until it snaps into place.

ITEM	PART DESCRIPTION	PART NUMBER	QTY
1	Syringe Tip	113-030	1
2	Syringe Tip Nut.....	113-402	1
3	O-Ring, 006	017-006	2
4	O-Ring, 228-040.....	017-023	1
5	Syringe Tip Adapter	113-227	1
6	O-Ring, 003	017-003	1
7	Syringe Head.....	113-405	1
8	Syringe Button Repair Kit.....	113-403	2
9	Pin, Syringe Cartridge	113-008	1
10	Plastic Washer, 8-32.....	003-030	2
11	Barb, 8-32 x 1/16"	022-040	2
12	Syringe Handle.....	113-236	1

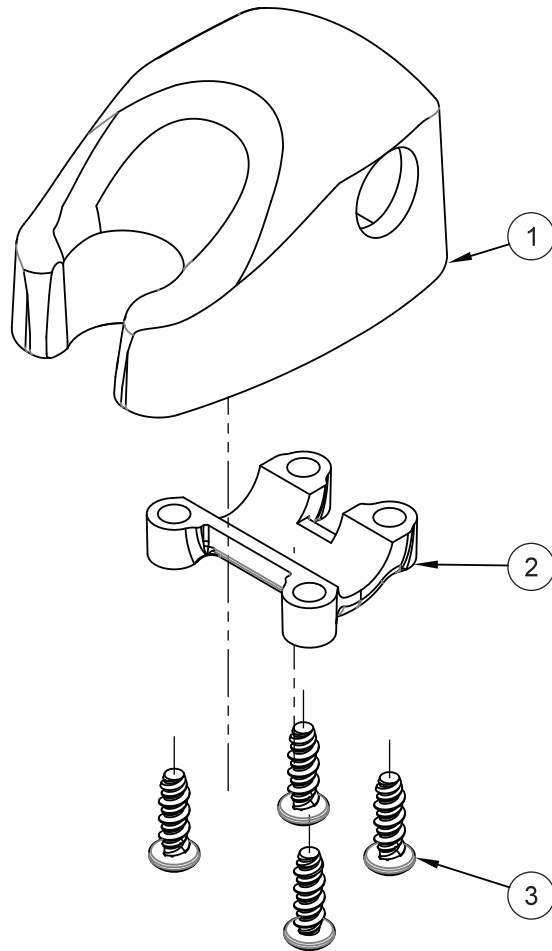

ITEM	PART DESCRIPTION	PART NUMBER	QTY
1	Molded Body.....	141-201	1
2	Clamp	122-204	1
3	Screw, 8-32 x 1/2".....	001-267	4

WARRANTY

BDS warrants its product to be free of defects in material and workmanship for SEVEN FULL YEARS from the date of purchase on all units. Auto-blocks and standard foot controls are covered by a LIFETIME warranty when factory installed as part of a complete dental system. Upholstery has a TWO YEAR warranty and does not cover normal wear, stains, cuts or tears. Our LED lights have a FIVE year Warranty and our halogen light has a ONE year Warranty. Operatory chair motors feature a TEN year warranty. All warranty is limited to repair or replacement by BDS. Products returned to the factory and determined to be defective will be repaired or replaced free of charge at discretion of BDS. The warranty does not cover light bulbs, electrical components and trimmed or installed tubing. BDS reserves the right to void all warranties if any product is installed by other than an authorized technician. BDS' warranty does not cover damage to any surface finish, including but not limited to, discoloration or abrasion from cleaners, disinfectants or light sources. No claim for labor or consequential damages will be allowed. Return items must include a copy of the invoice or packing slip as proof of purchase.

**Beaverstate Dental Inc.
115 S. Elliott Rd.
Newberg, OR 97132
800-237-2303
503-538-8756
503-538-2845 Fax
www.beaverstatedental.com**
