



Service Manual

A-3103

3 HP Automatic

Mobile System

Installation

Under Cabinet Mount

1. Place the shipping carton in the desired location. Remove the unit from the shipping carton.
2. Remove the full sized mounting template from the service manual. Place in desired location and mark four places to be drilled. We recommend the faceplate to be offset inward 1/8" from the front of the counters edge.
3. Pre-drill a hole 1/2" deep using a 5/32" drill bit. Do not drill through the counter top
4. Slide the unit apart by seperating the faceplate assembly from the fixed body assembly. With the unit fully extended, line up the outer chassis aligning the holes with the pre-drilled holes. Place a 1/4" Hex Screw in one corner to lightly fasten it using a 3/8" Hex Drive. Repeat the process until all four screws are installed. Tighten securely making sure the face plate slides in and out freely.
5. Insert the umbilical tubing in first and follow with the unit.
6. Mount the holder bar with holders in desired location under counter top.



NOTE

This unit requires a regulated air and water supply. Filters are highly recommended.

7. Install optional master valve assemblies, with filter and regulator, onto the manual shut-off valves. (Pressures are preset at the factory: 80 psi air, 40 psi water).
8. Connect the supply tubings to the appropriate air and water supply lines.

Final Adjustments

Check air pressure, adjust to 80 psi if necessary.
Check water pressure, adjust to 40 psi if necessary.
Test handpieces for proper function.
Test syringe for proper pressure and function.

A-3103

- Operation**
1. Turn on the master switch located on the right side of the faceplate.
 2. The handpiece is automatically activated when lifted from the holder.
 3. Depress the foot control to activate each handpiece. Pressure is shown on the gauge for the handpiece being used.
 4. Individual handpiece pressure adjustments are located on the autoblock inside the unit. To adjust the pressure to each handpiece:
 - a. Turn adjustment screw *clockwise* to decrease the handpiece pressure.
 - b. Turn adjustment screw *counter-clockwise* to increase the handpiece pressure.



CAUTION

When adjusting the handpiece pressure, do not over-tighten the screws. Damage may result.

5. Handpiece coolant water can be turned on or off with the toggle switch located in the lower center of the faceplate.
6. Water coolant flow adjustment is located to the right of the water coolant toggle switch.

Handpiece Purge The purge switch flushes fresh water through the water coolant system. Guidelines from the Center for Disease Control (CDC) recommends that each handpiece be flushed (purged) 20 to 30 seconds between patients and several minutes at the beginning of each day. Handpieces must be removed from the holder to activate the purge system.

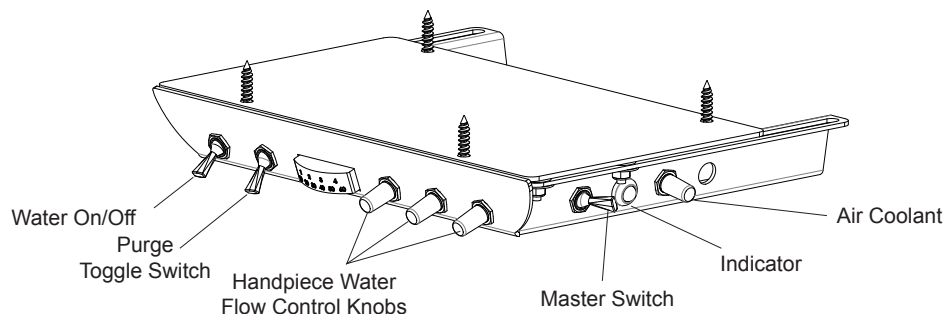

Control Panel A-3103

Troubleshooting

Symptom Handpiece lacks power.

- Possible Causes
- A. Improper supply pressure from compressor (80 psi).
 - B. Check handpiece pressure adjustment on unit.
 - C. Air filter may be plugged.
 - D. Pinched supply tubing.
 - E. Defective handpiece gasket at connection with tubing.
 - F. Defective handpiece.

Symptom Water coolant does not shut off when foot control is released.

- Possible Causes
- A. Adjust air pressure to 80 psi—water pressure to 40 psi.
 - B. Foot control is not exhausting.
 - C. Defective water relay valve.

Symptom More than one handpiece is operating.

- Possible Causes
- A. Handpiece is not all the way in the holder.
 - B. Improper adjustment on pilot valve in the handpiece holder.
 - C. Defective shuttle valve to gauge.

Symptom Insufficient water coolant.

- Possible Causes
- A. Adjust coolant flow valve.
 - B. Water filter may be plugged.
 - C. Handpiece may be plugged.
 - D. Pinched supply tubing.
 - E. Improper adjustment of water relay valve

Symptom Water coolant is running from handpiece while in the holder.

- Possible Causes
- A. Water pressure too high.
 - B. Air pressure too low.
 - C. Handpiece holder out of adjustment.

Symptom Water coolant is running continuously.

- Possible Causes
- A. Purge switch is on (on applicable systems).
 - B. Water pressure too high.
 - C. Handpiece holder out of adjustment.
 - D. Defective water relay valve.

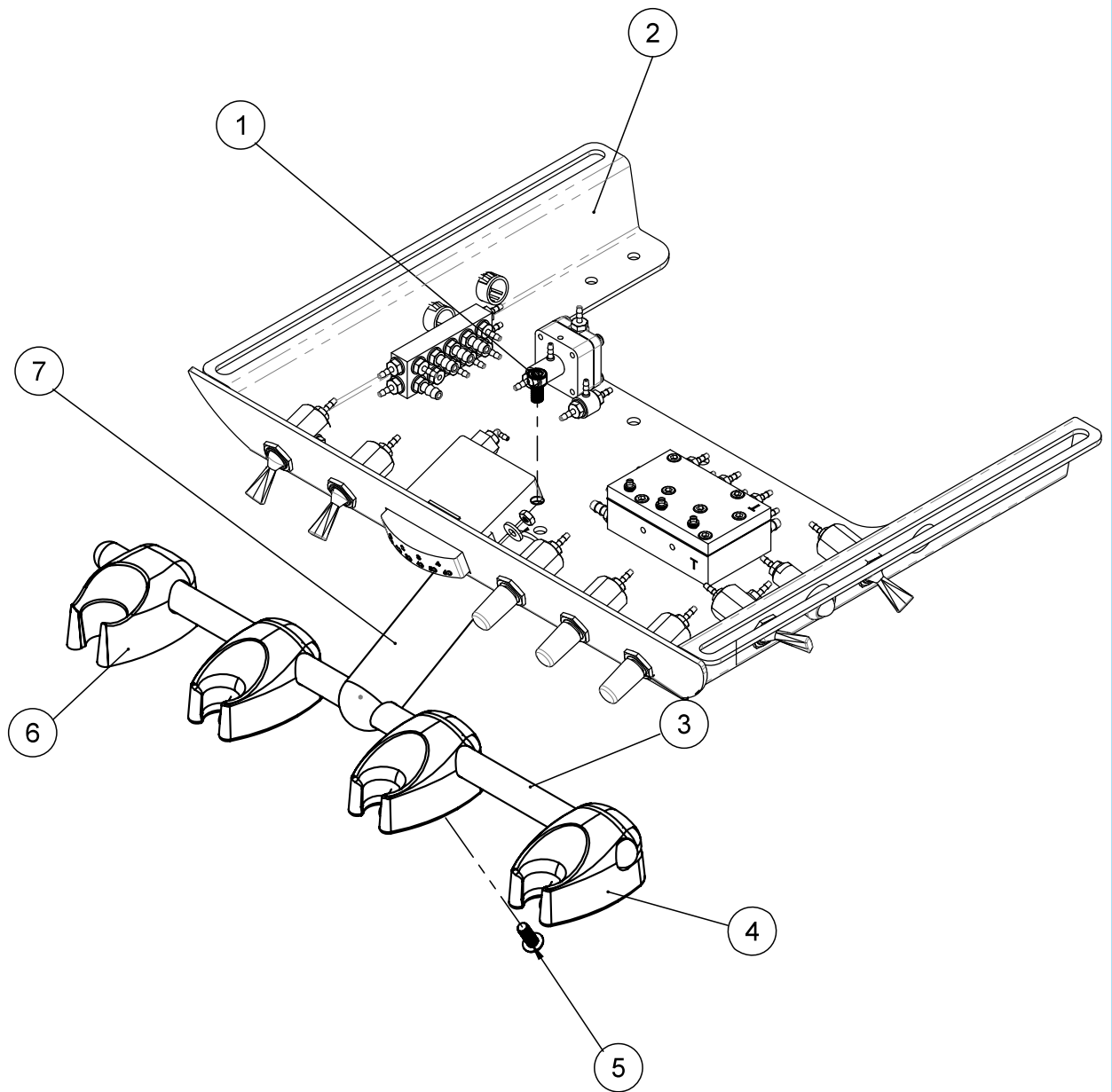

ITEM	PART DESCRIPTION	PART NUMBER	QTY
1	Screw, 10-32 x 3/8"	001-156	2
2	Rear Delivery Unit Head	3100-RD	1
3	Holder Bar 12.5"	107-003	1
4	Auto Holder	122-200	3
5	Screw, 10-32 x .50	001-171	1
6	Syringe Holder	141-200	1
7	Holder Bar Mount	107-007	1

**REAR DELIVERY 3 HP SINGLE SWIVEL
A-3103**

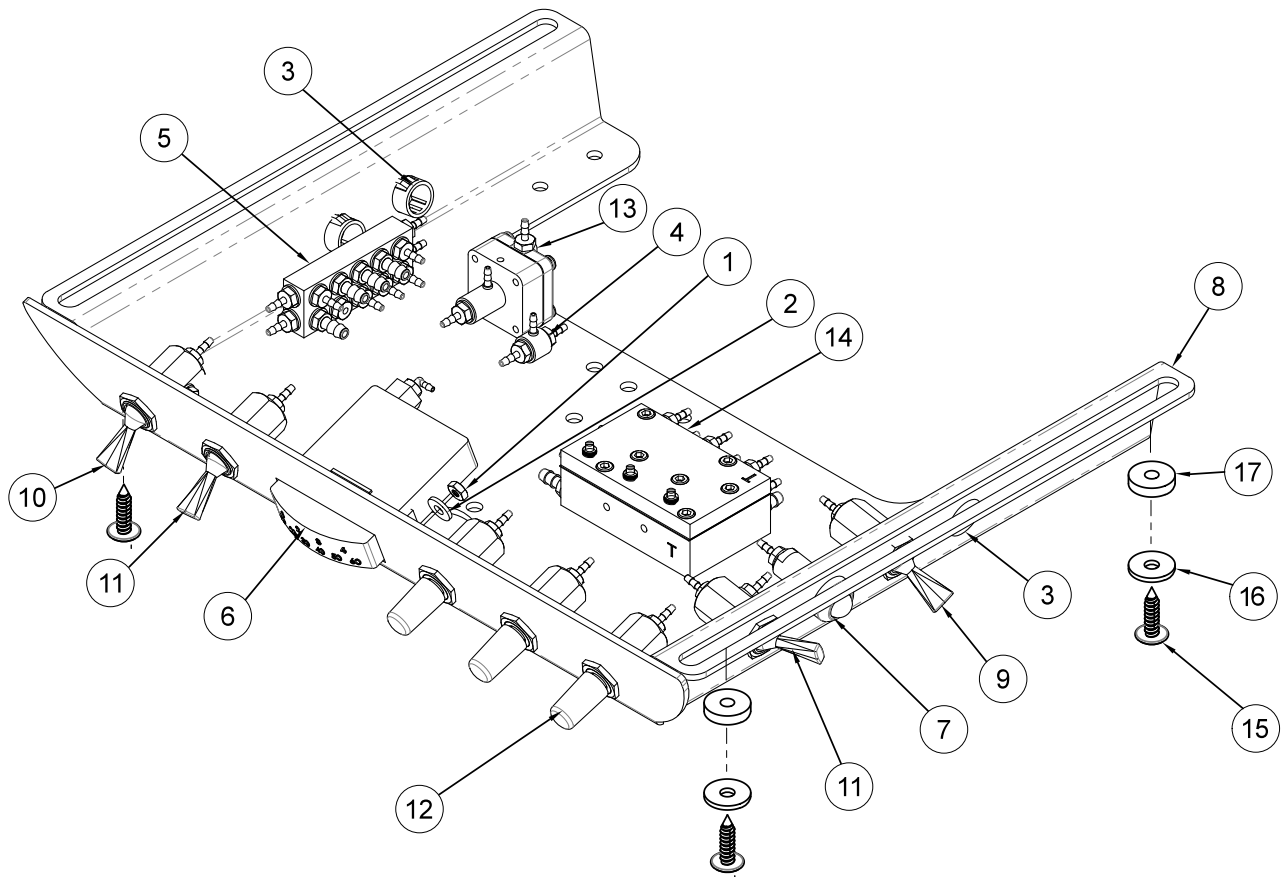

ITEM	PART DESCRIPTION	PART NUMBER	QTY
1	4-40 Hex Nut	002-017	2
2	Washer, No. 6	003-032	2
3	1/2" Plug.....	010-013	3
4	Shuttle Valve.....	014-012	1
5	Manifold.....	023-003	1
6	Rectangular Gauge.....	026-003	1
7	Pneumatic Indicator.....	026-020	1
8	Chassis.....	103-330	1
9	3 Way Momentary Toggle Valve.....	120-005	1
10	3 Way Toggle Valve	120-007	1
11	3 Way Toggle Valve.....	120-000	2
12	Needle Flow Valve.	121-000	3
13	Water Relay Valve	123-000	1
14	Autoblock.....	125-030	1
15	Screw, 18-8.....	001-270	4
16	Washer, 0625 OD x .199	003-070	4
17	Spacer, A-Series.....	103-334	4

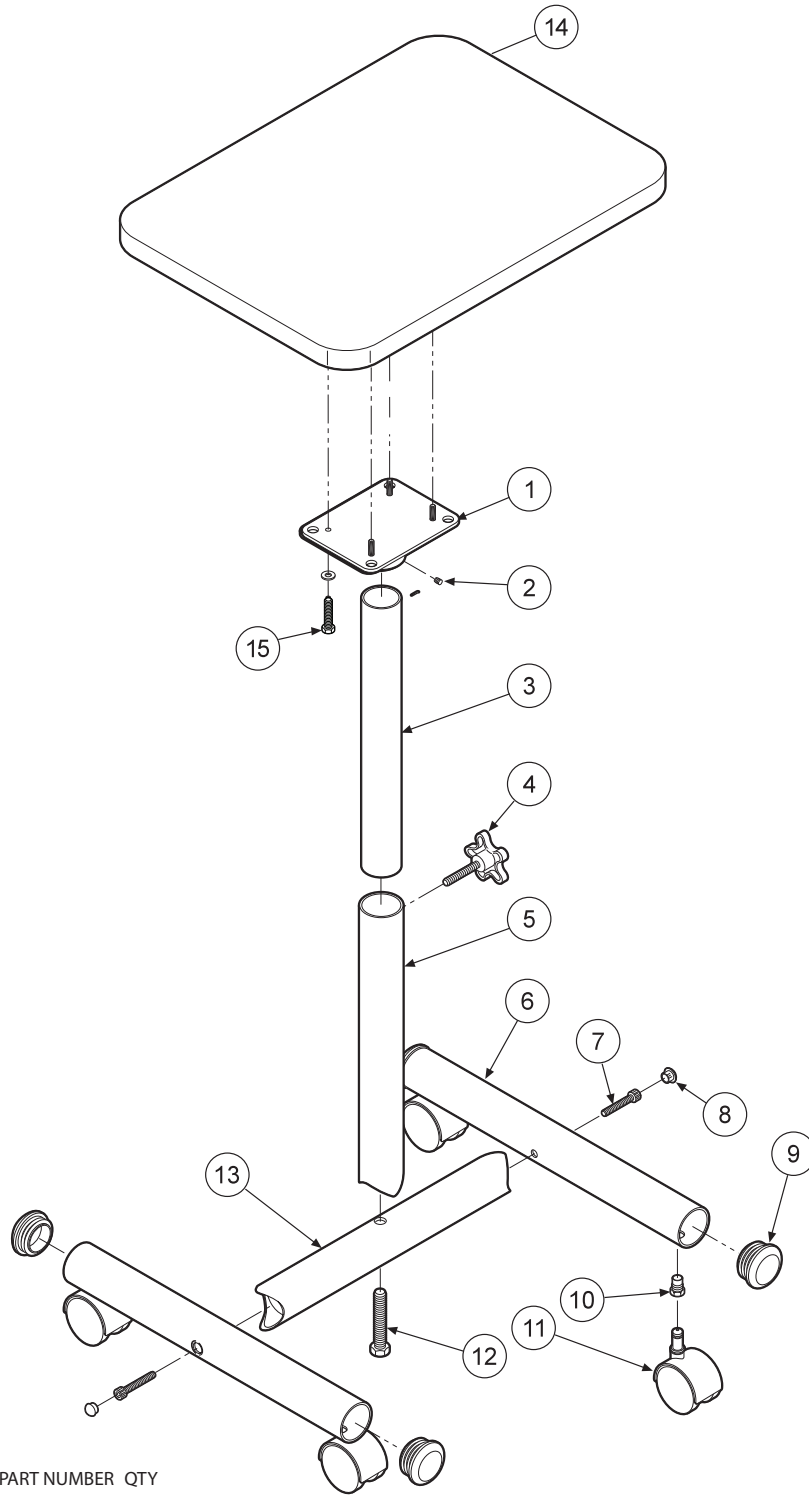

ITEM	PART DESCRIPTION	PART NUMBER	QTY
1	Cart Top Hub	108-029	1
2	Set Screw, 1/4-20 x 1/4"	005-044	4
3	Inner Tube	108-025	1
4	Height Adjustment Knob	010-058	1
5	Stand Tube	108-024	1
6	Side Tube	108-022	2
7	Screw, 3/8-16 x 1-1/2"	001-165	2
8	Plug	010-041	2
9	Bumper	010-059	4
10	Caster Socket	108-032	4
11	Casters	108-007	4
12	Screw, 1/2-13 x 3"	001-164	1
13	Center Tube	108-023	1
14	Cart Top	101-113	1
15	Screw, 1/4-20 x 3/4"	001-022	4

CART FRAME & TOP

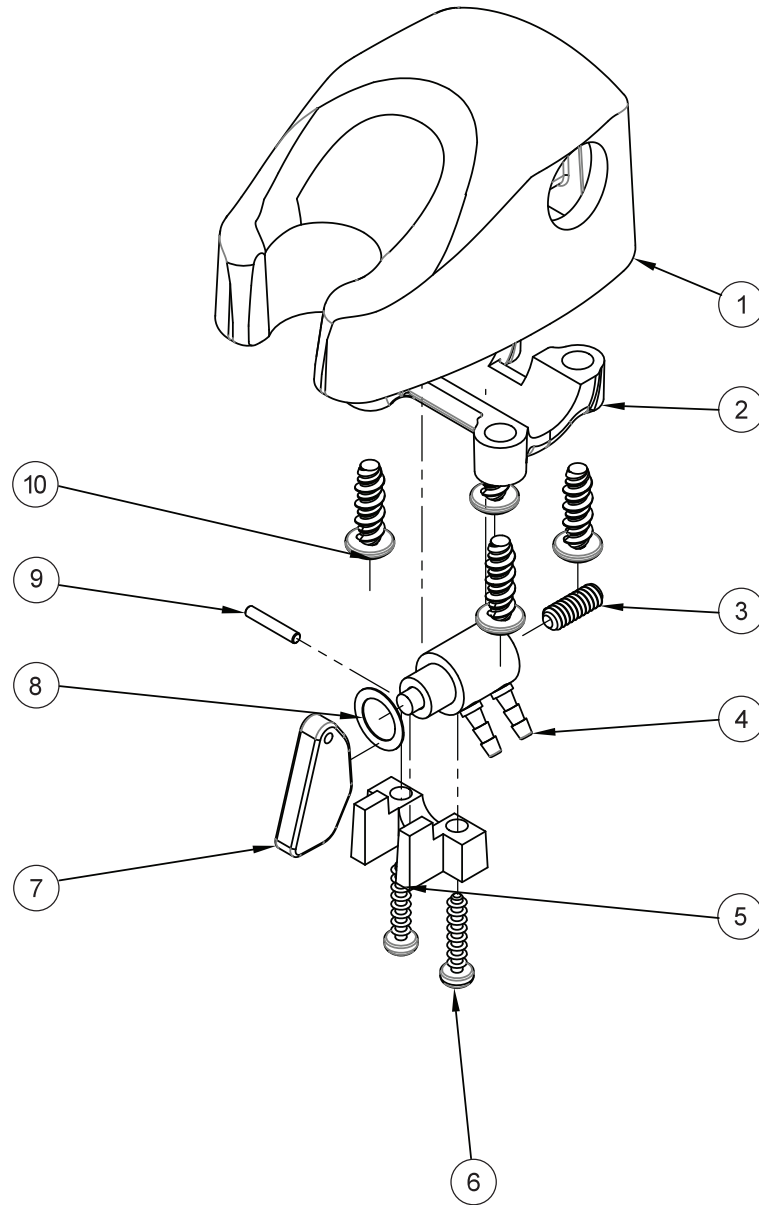

ITEM	PART DESCRIPTION	PART NUMBER	QTY
1	Molded Body.....	122-201	1
2	Clamp	122-104	1
3	Set Screw, 6-32 x 3/8".....	005-012	1
4	Valve Cartridge.....	122-031	1
5	Molded Clip.....	122-102	1
6	Screw, 4 x 1/2"	001-019	2
7	Handpiece Actuator Lever.....	122-103	1
8	Washer.....	003-004	1
9	Pin, 1/16"x3/8" Dowel.....	009-010	1
10	Screw, 8-18 x 1/2".....	001-267	4

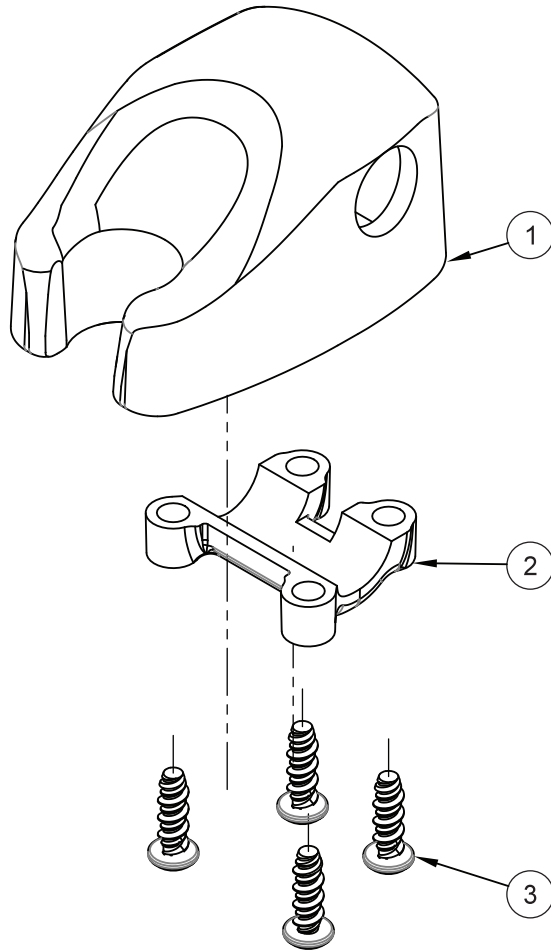

ITEM	PART DESCRIPTION	PART NUMBER	QTY
1	Molded Body.....	141-201	1
2	Clamp	122-204	1
3	Screw, 8-32 x 1/2"	001-267	4

MOLDED IC UNIVERSAL HOLDER
141-200

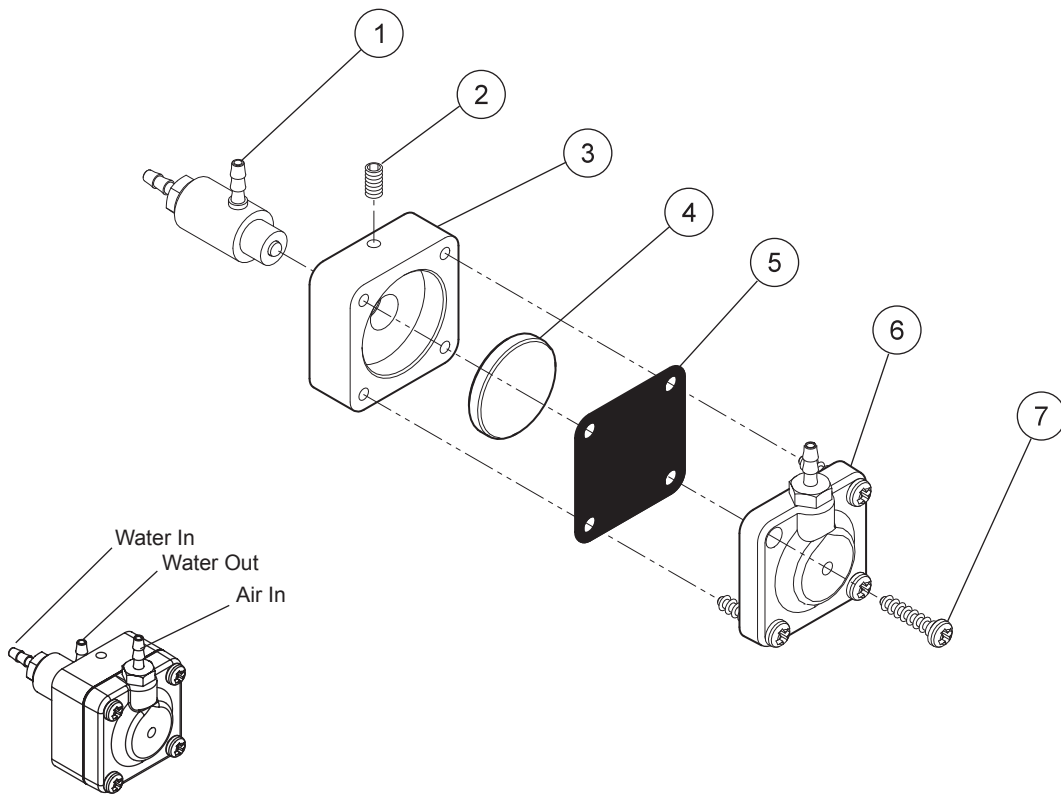
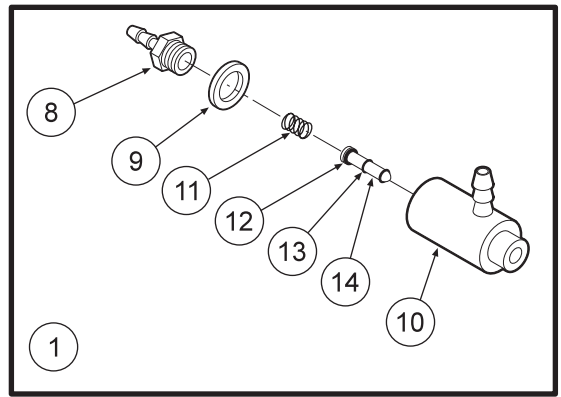

Water Relay Valve 123-000

ITEM	PART DESCRIPTION	PART NUMBER	QTY
1	Cartridge Body Assembly.....	123-018	1
2	Set Screw, 4-40 x 5/8".....	005-028	1
3	Body.....	123-013	1
4	Piston.....	123-014	1
5	Diaphragm.....	127-031	1
6	Cap.....	123-012	1
7	Screw, #6 x 1/2".....	001-267	4
8	Barb, 10-32 x 1/16".....	022-009	1
9	Plastic Washer, 1/4".....	003-001	1
10	Valve Body.....	123-017	1
11	Spring.....	008-011	1
12	O-Ring, 002.....	017-502	1
13	O-Ring, 001.....	017-501	2
14	Stem.....	123-015	1

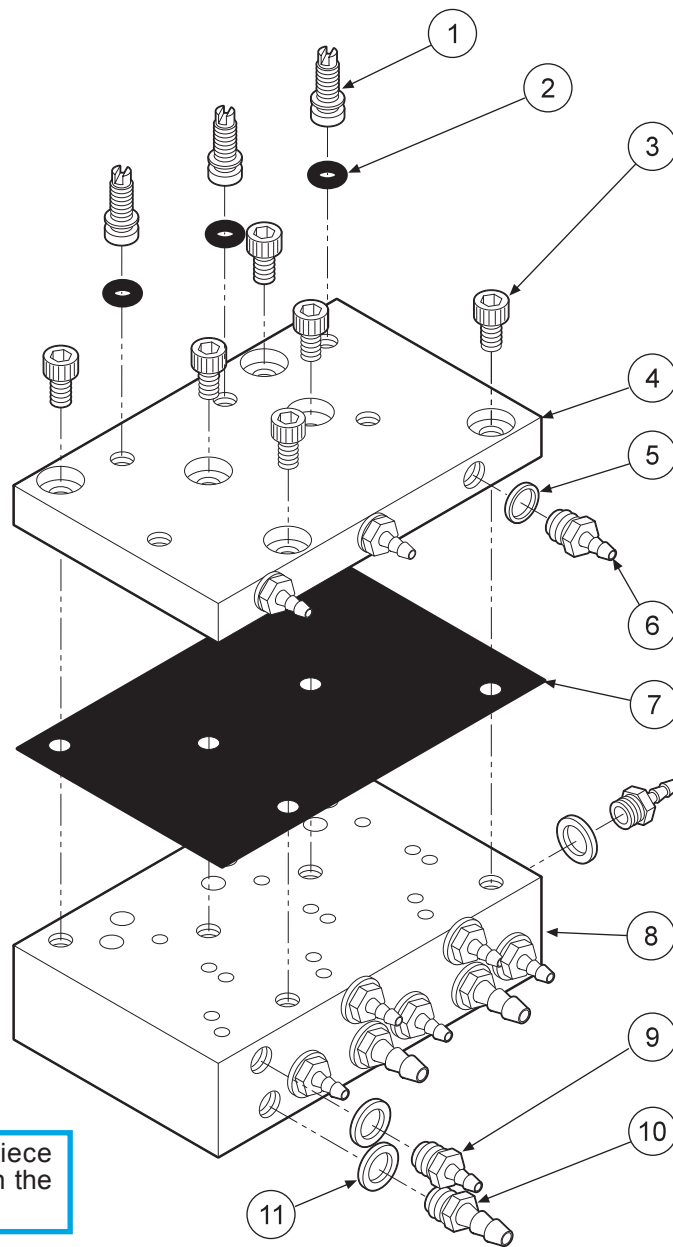

CAUTION
When adjusting the handpiece pressure, do not over-tighten the screws. Damage may result.

The automatic control block is the control center for your dental unit.

Individual handpiece pressure adjustments are located on the autoblock. To adjust the pressure to each handpiece:

- a. Turn adjustment screw clockwise to decrease the handpiece pressure.
- b. Turn adjustment screw counter-clockwise to increase the handpiece pressure.

ITEM	PART DESCRIPTION	PART NUMBER	QTY
1	Adjusting Stem.....	125-023	3
2	O-Ring, 021.....	017-021	3
3	Screw, 6-32 x 1/4".....	001-131	7
4	Cap.....	125-032	1
5	Plastic Washer, 8-32 x 1/16".....	003-030	3
6	Barb, 8-32 x 1/16".....	022-040	3
7	Diaphragm.....	125-016	1
8	Body.....	125-031	1
9	Barb, 10-32 x 1/16".....	022-009	9
10	Barb, 10-32 x 1/8".....	022-010	4
11	Plastic Washer, 1/4".....	003-001	13

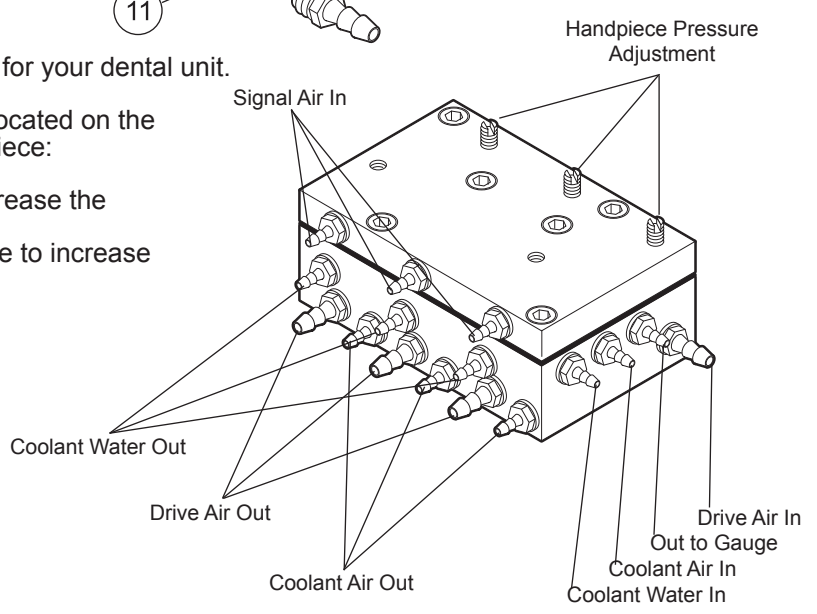

AUTOMATIC HANDPIECE CONTROL BLOCK
125-030

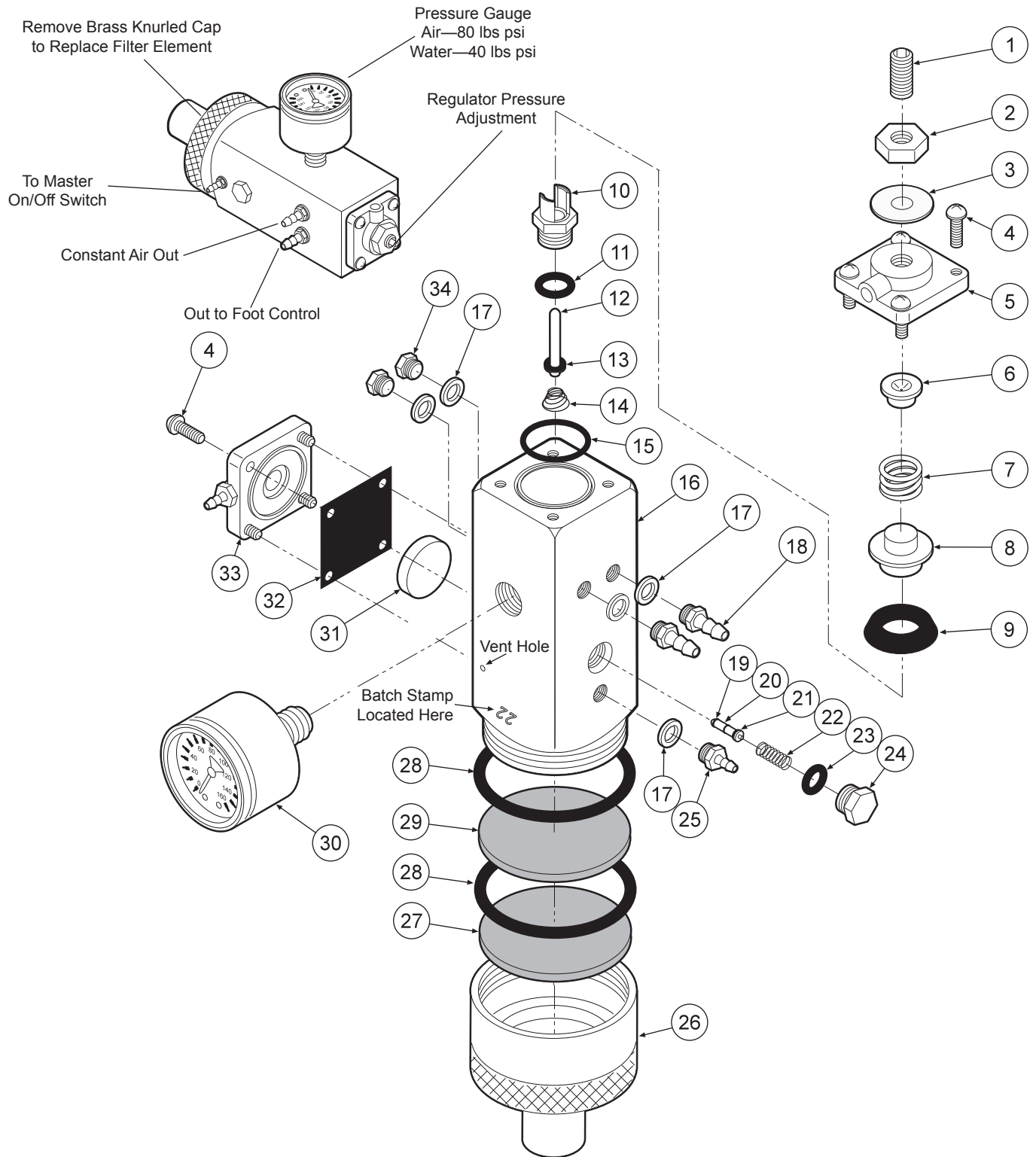

ITEM	PART DESCRIPTION	PART NUMBER	QTY	ITEM	PART DESCRIPTION	PART NUMBER	QTY	ITEM	PART DESCRIPTION	PART NUMBER	QTY
1	Set Screw, 1/4-20 x 5/8"	005-024	1	13	O-Ring, 004	017-104	1	24	Plug	020-026	1
2	Jam Nut, 1/4-20	002-006	1	14	Spring	008-028	1	25	Barb, 10-32 x 1/16"	022-009	1
3	Washer	003-015	1	15	O-Ring	017-018	1	26	Cap Inlet	127-041	1
4	Screw, 6-32 x 3/8"	001-041	8	16	Body	127-040	1	27	Filter Element, 100 Micron	119-005	1
5	Cap	127-033	1	17	Plastic Washer, 1/4"	003-001	5	28	O-Ring, 018	017-022	2
6	Spring Seat	127-043	1	18	Barb, 10-32 x 1/8"	022-010	2	29	Filter Element, 35 Micron	119-004	1
7	Spring	008-008	2	19	O-Ring, 001	017-501	2	30	Gauge	026-001	1
8	Cup Seat	127-044	1	20	Stem	127-045	1	31	Piston	123-014	1
9	Cup Seal	017-200	4	21	O-Ring, 003	017-103	1	32	Gasket	127-031	1
10	Seat	127-026	3	22	Spring	008-040	1	33	Cap	123-030	1
11	O-Ring, 008	017-008	2	23	O-Ring, 007	017-007	1	34	Plug	001-001	2
12	Stem	127-024	1								

Remove Brass Knurled Cap to Replace Filter Element

Pressure Gauge
Air—80 lbs psi
Water—40 lbs psi

Water Out

Regulator Pressure Adjustment

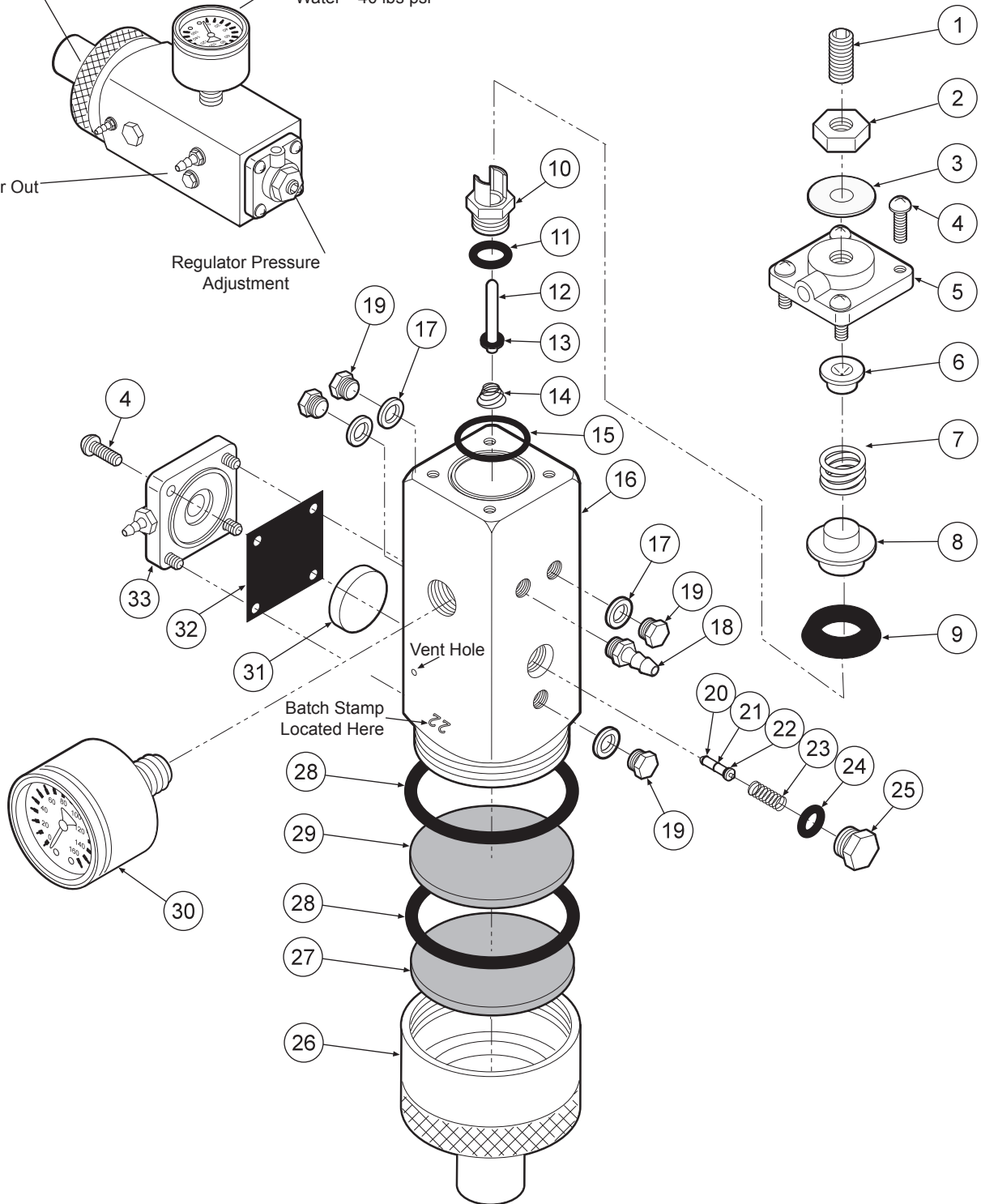

ITEM	PART DESCRIPTION	PART NUMBER	QTY	ITEM	PART DESCRIPTION	PART NUMBER	QTY	ITEM	PART DESCRIPTION	PART NUMBER	QTY
1	Set Screw, 1/4"-20 x 5/8"	005-024	1	12	Stem	127-024	1	23	Spring	008-040	1
2	Jam Nut, 1/4"-20	002-006	1	13	O-Ring, 004	017-104	1	24	O-Ring, 007	017-007	1
3	Washer	003-015	1	14	Spring	008-028	1	25	Plug	020-026	1
4	Screw, 6-32 x 3/8"	001-041	8	15	O-Ring	017-018	1	26	Cap Inlet	127-041	1
5	Cap	127-023	1	16	Body	127-040	1	27	Filter Element, 100 Micron	119-005	1
6	Spring Seat	127-043	1	17	Plastic Washer, 1/4"	003-001	1	28	O-Ring, 018	017-022	2
7	Spring	008-008	1	18	Barb, 10-32 x 1/8"	022-010	1	29	Filter Element, 35 Micron	119-004	1
8	Cup Seat	127-044	1	19	Plug	001-001	4	30	Gauge	126-001	1
9	Cup Seal	017-200	1	20	O-Ring, 001	017-501	2	31	Piston	123-014	1
10	Seat	127-026	1	21	Stem	127-045	1	32	Gasket	127-031	1
11	O-Ring, 008	017-008	1	22	O-Ring, 003	017-103	1	33	Cap	123-012	1

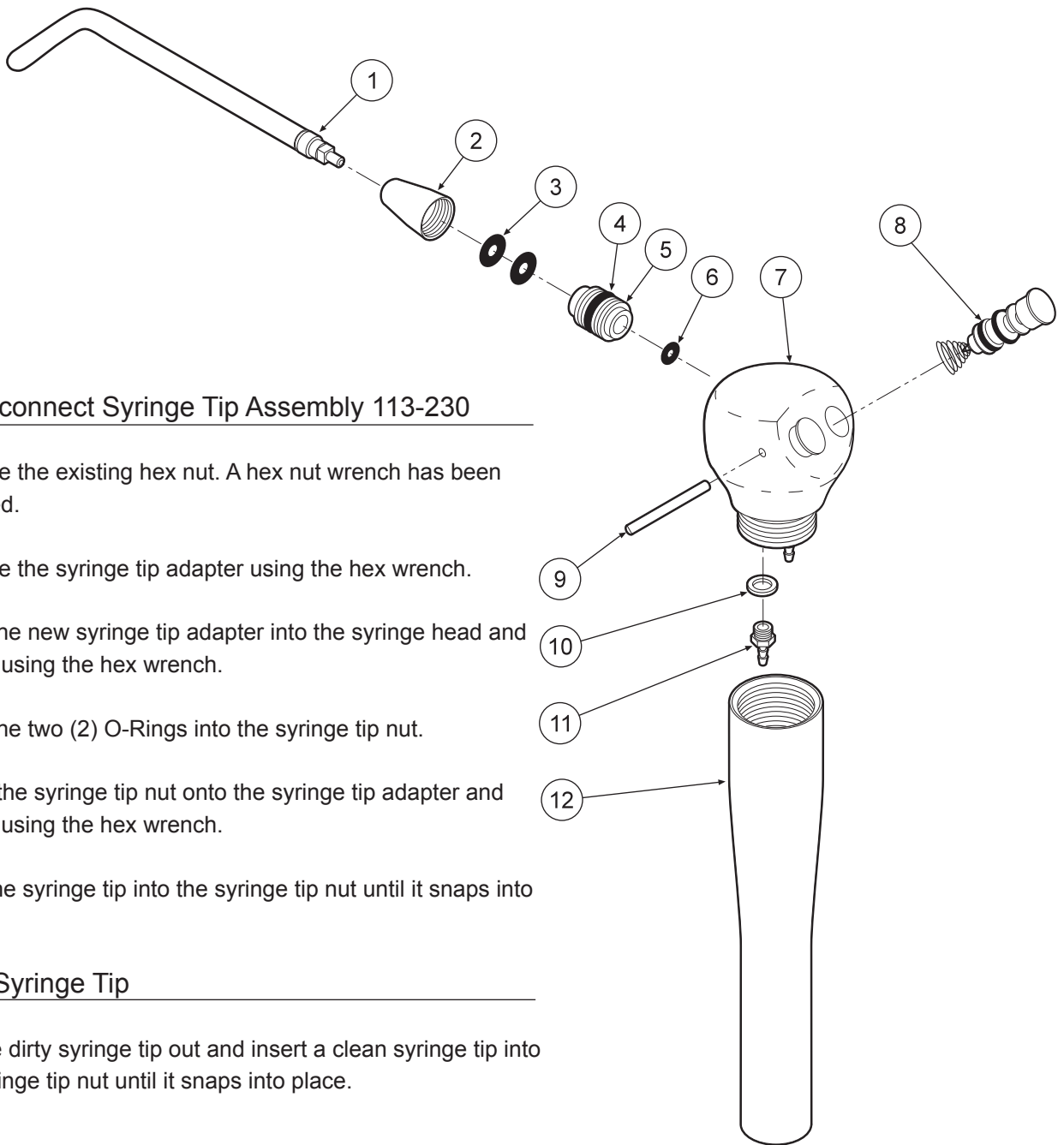

Quick-disconnect Syringe Tip Assembly 113-230

1. Remove the existing hex nut. A hex nut wrench has been provided.
2. Remove the syringe tip adapter using the hex wrench.
3. Insert the new syringe tip adapter into the syringe head and tighten using the hex wrench.
4. Place the two (2) O-Rings into the syringe tip nut.
5. Screw the syringe tip nut onto the syringe tip adapter and tighten using the hex wrench.
6. Push the syringe tip into the syringe tip nut until it snaps into place.

Replace Syringe Tip

1. Pull the dirty syringe tip out and insert a clean syringe tip into the syringe tip nut until it snaps into place.

ITEM	PART DESCRIPTION	PART NUMBER	QTY
1	Syringe Tip	113-030	1
2	Syringe Tip Nut.....	113-402	1
3	O-Ring, 006.....	017-006	2
4	O-Ring, 228-040.....	017-023	1
5	Syringe Tip Adapter.....	113-227	1
6	O-Ring, 003.....	017-003	1
7	Syringe Head.....	113-405	1
8	Syringe Button Repair Kit.....	113-403	2
9	Pin, Syringe Cartridge.....	113-008	1
10	Plastic Washer, 8-32.....	003-030	2
11	Barb, 8-32 x 1/16".....	022-040	2
12	Syringe Handle.....	113-236	1

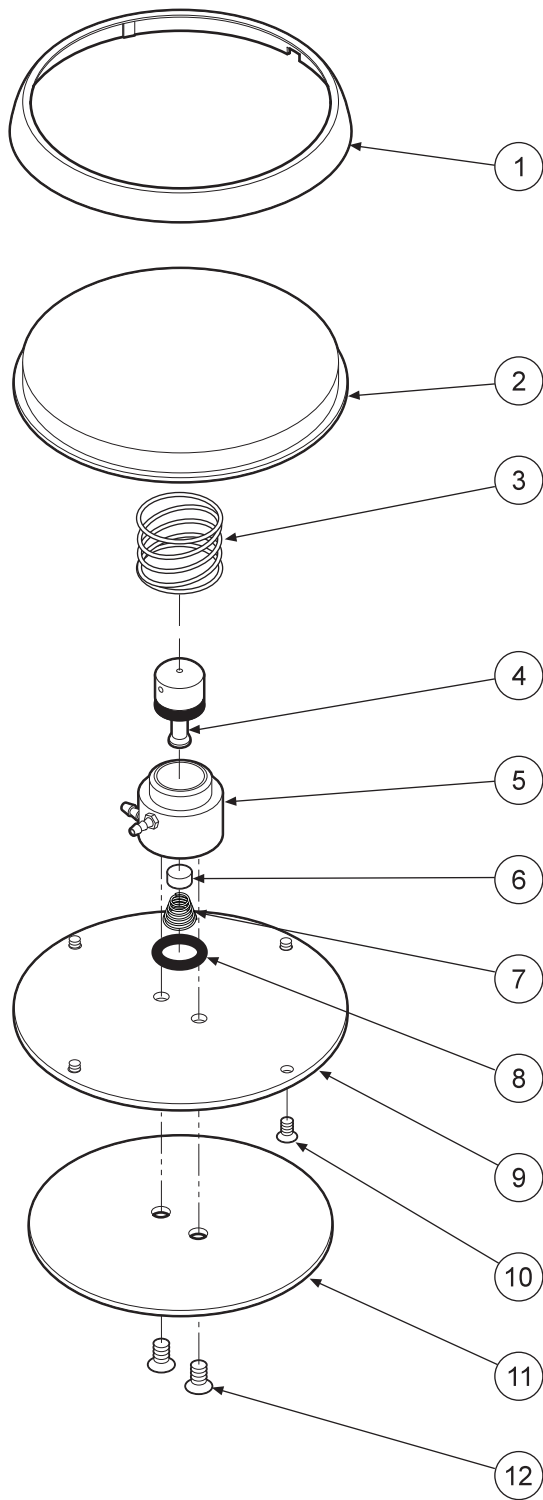

ITEM	PART DESCRIPTION	PART NUMBER	QTY
1	Ring.....	126-202	1
2	Cover.....	126-201	1
3	Spring.....	008-005	1
4	Stem (Includes 017-012 o-ring).....	126-005	1
5	Body.....	126-004	1
6	Poppet.....	126-006	1
7	Spring.....	008-006	1
8	O-Ring, 013.....	017-013	1
9	Baseplate.....	126-003	1
10	Screw, 4-40 x 1/4".....	001-005	4
11	Rubber Pad.....	126-007	1
12	Screw, 6-32 x 1/4".....	001-004	2

FOOT CONTROL
126-200



3 Handpiece Automatic Mobile System A-3103

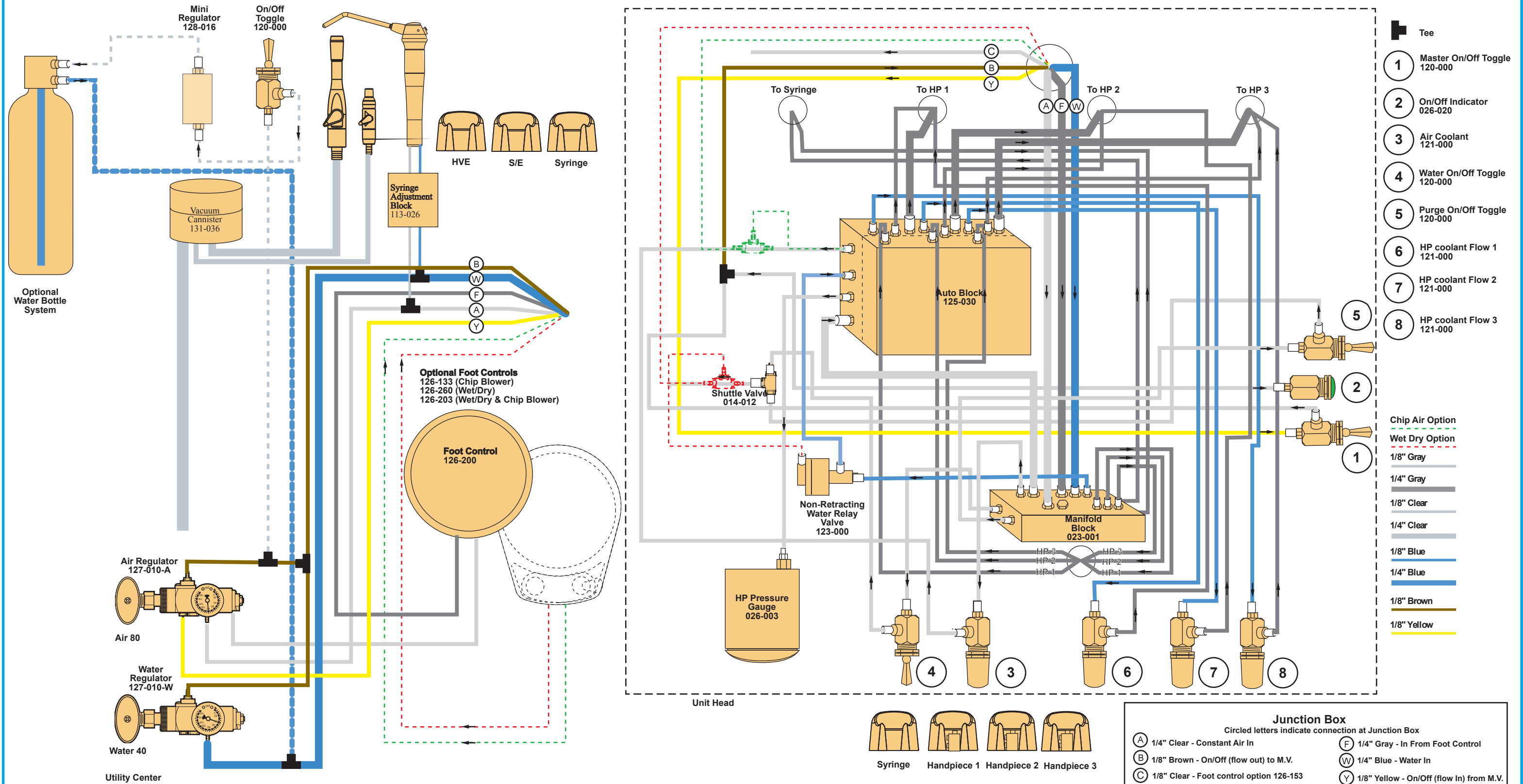

WARRANTY

BDS warrants its product to be free of defects in material and workmanship for SEVEN FULL YEARS from the date of purchase on all units. Auto-blocks and standard foot controls are covered by a LIFETIME warranty when factory installed as part of a complete dental system. Upholstery has a TWO YEAR warranty and does not cover normal wear, stains, cuts or tears. Our LED lights have a FIVE year Warranty and our halogen light has a ONE year Warranty. Operatory chair motors feature a TEN year warranty. All warranty is limited to repair or replacement by BDS. Products returned to the factory and determined to be defective will be repaired or replaced free of charge at discretion of BDS. The warranty does not cover light bulbs, electrical components and trimmed or installed tubing. BDS reserves the right to void all warranties if any product is installed by other than an authorized technician. BDS' warranty does not cover damage to any surface finish, including but not limited to, discoloration or abrasion from cleaners, disinfectants or light sources. No claim for labor or consequential damages will be allowed. Return items must include a copy of the invoice or packing slip as proof of purchase.

**Beaverstate Dental Inc.
115 S. Elliott Rd.
Newberg, OR 97132
800-237-2303
503-538-8756
503-538-2845 Fax
www.beaverstatedental.com**
